

## DETONATION CONTROL MODULE REPLACEMENT - 200 HP, EFI

### Models Affected

#### MERCURY/MARINER

1996 200 HP, EFI

S/N 0G373511 thru 0G406826

A condition has been identified that could cause a failure of the Detonation Control Module P/N 826800A8 marked 826800A5 used on 200 HP Electronic Fuel Injection (EFI) engines. Voids in the potting that surrounds the printed circuit board could cause an early failure. Failure could cause loss of timing control and inability to correct for a detonation condition.

This void has only occurred on detonation control modules using the new style textured finish plastic housing. The detonation control modules affected by this condition have date codes 3055 thru 0446. The textured finish plastic housing has a dull appearance, compared to the previous box that had a shiny/glossy finish.

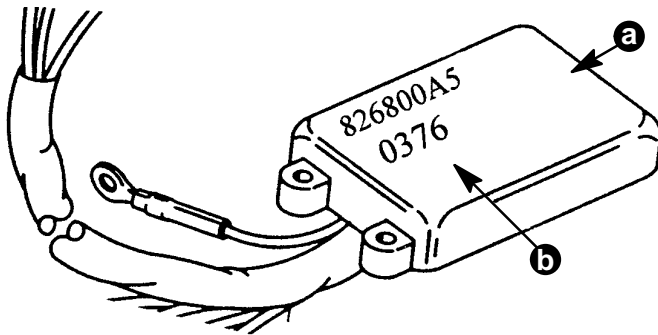

a - Detonation control module  
b - Date code and part number

Date code explanation:

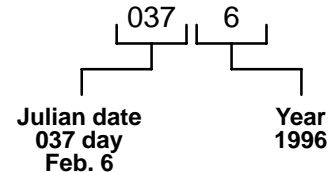

### OWNER NOTIFICATION:

A combination letter/claim (USA) or a letter (CAN-ADA) will be sent to every registered owner of an affected outboard. The letter will advise the owner to return their outboard to their selling dealer or an authorized dealer for replacement of the detonation control module. A copy of the letter/claim is included with this Service Bulletin.

### CORRECTION:

At the top of the engine there are two modules mounted one above the other. The upper module is the detonation control. It has part number 826800A5 marked on it with white ink. If this module has a textured finish and has a date code between 3055 thru 0446, replace the module with P/N 826800A8. The replacement module will have a shiny/glossy finish with the part number 826800A5 marked on it.

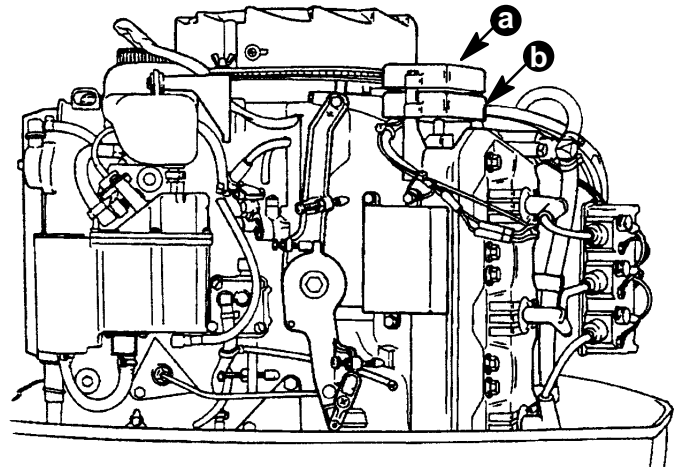

a - Detonation control module  
b - Oil injection warning module

**REWORK/PART IDENTIFICATION:**

Outboards within the serial number range listed that have been reworked at the factory are identified by:

- A green dot on the outside of the engine carton near the serial number.
- Engines will have a detonation control module with a shiny/glossy finish and a green dot on the module.

**DEALER OUTBOARD INVENTORY:**

Affected outboards in dealer inventory **MUST BE** reworked prior to customer delivery.

**SERVICE PARTS STOCK:**

Inspect all P/N 826800A8 detonation control modules in your service stock. Return with a warranty claim any detonation control modules with textured finish between date code 3055 thru 0446.

**WARRANTY - MODULE INSTALLED ON ENGINE:**

Complete a warranty claim listing.

- Engine serial number (one serial number per claim).
- Qty. one (1) p/n 826800A8 detonation control module
- (1.0) hours labor
- Flat Rate code: NJC
- Failure code 376 40

US and CANADA: Return with a warranty claim.

INTERNATIONAL: Follow instructions issued by Marine Power International office or by your distributor.

**WARRANTY - MODULE IN DEALER STOCK:**

Complete a warranty claim listing.

- Qty. (as required) P/N 826800A8
- 2 tenth (0.2) hour labor
- Flat rate code NJC
- Failure code 376 40

US and CANADA: Return with a warranty claim.

INTERNATIONAL: Follow instructions issued by Marine Power International office or by your distributor.



A BRUNSWICK COMPANY

W6250 W. PIONEER ROAD  
P.O. BOX 1939  
FOND DU LAC, WI 54936-1939 U.S.A.

PHONE (414) 929-5000 ■ FAX (414) 929-5060

---

Dear Owner:

Our records indicate you own a Mercury or Mariner outboard that may have a faulty detonation control module. If this component fails, your engine may be susceptible to piston failure.

**WHAT YOU SHOULD DO**

Contact your authorized Mercury Marine dealer, preferably the one who sold you the engine. Make an appointment to have this work done under Service Bulletin 96-5.

Then, deliver your outboard and this letter to your dealer at the appointed time. The reverse side of this letter is a claim your dealer needs to send us for reimbursement.

**WHAT WE WILL DO**

We will reimburse the authorized dealer for repairing the engine. You will not be charged for this procedure.

We regret and sincerely apologize for any inconvenience this recall may have caused you.

However, we have taken this action to insure your boating enjoyment and continued satisfaction with our product.

Sincerely,

Mercury Marine

A handwritten signature in black ink that reads "Bob Kachelek".

Bob Kachelek  
Director, Outboard Service



A BRUNSWICK COMPANY  
MERCURY MARINER MERCURUISER FORCE QUICKSILVER

# WARRANTY CLAIM

ENGINE SERIAL NUMBER: \_\_\_\_\_

DATE RECEIVED: \_\_\_\_\_ AM \_\_\_\_\_ PM \_\_\_\_\_ DATE PROMISED: \_\_\_\_\_ AM \_\_\_\_\_ PM \_\_\_\_\_

CUSTOMER NAME: \_\_\_\_\_ DEALER CODE: \_\_\_\_\_

ADDRESS: \_\_\_\_\_ DEALER NAME: \_\_\_\_\_

CITY, STATE, ZIP: \_\_\_\_\_ DEALER ADDRESS: \_\_\_\_\_

MODEL / SERIAL NUMBER: \_\_\_\_\_ CITY, STATE, ZIP: \_\_\_\_\_

DATE OF SALE: \_\_\_\_\_ ORDER NUMBER: \_\_\_\_\_ LABOR RATE: \_\_\_\_\_

DESCRIPTION OF FAILURE: Ref Service Bulletin 96-5

FAILURE CODE: 376-40 FAILURE CODE DESCRIPTION: Detonation Mod/Fix

NOTE: WARRANTY CLAIM MUST BE RECEIVED WITHIN 30 DAYS OF REPAIR DATE TO BE CONSIDERED FOR APPROVAL

PRE-AUTHORIZATION NUMBER: \_\_\_\_\_ ENTER DATE: \_\_\_\_\_

PRODUCT (CHECK ONE ONLY)

OUTBOARD

STERNDRIVE

INBOARD

INFLATABLES

JET

QUICKSILVER P&A (ATTACH RECEIPT)

OTHER - SPECIFY \_\_\_\_\_

DATE FAILED: \_\_\_\_\_

DATE REPORTED: \_\_\_\_\_

DATE REPAIRED: \_\_\_\_\_

HOURS USED: \_\_\_\_\_

BOAT TYPE: \_\_\_\_\_

H.I.N. \_\_\_\_\_

REPAIR PARTS IDENTIFICATION			LABOR PERFORMED PER FLAT RATE MANUAL					
QTY	PART NUMBER	PART DESCRIPTION	LIST PRICE	TOTAL	CODE	DESCRIPTION	HOURS	DOLLARS
1	826800A8	Detonation Control Mod.			NJC	No Job Code	1.0	
TOTAL LABOR								
TOTAL PARTS								
SUB TOTAL								
TAX								
SUBLET LABOR (RECEIPT ATTACHED)								
FREIGHT (ATTACH RECEIPT IF OVER \$10.00)								
GRAND TOTAL								

FOR FACTORY USE ONLY

I HEREBY AUTHORIZE THE ABOVE REPAIR WORK TO BE DONE AND GRANT YOU AND/OR YOUR EMPLOYEES PERMISSION TO OPERATE THE UNIT AS NECESSARY FOR TESTING AND/OR INSPECTION.

CUSTOMER AUTHORIZATION