

## Trigger Modification - 250/275

Mariner and Mercury

1989 thru 1992

250/275 Models

S/N 0D086817 and Below

Replacement Cylinder Block and Powerhead Assemblies

Replacement cylinder blocks and powerhead assemblies listed for older models have the new upper crankshaft bearing P/N 31-816773A1. The new upper crankshaft bearing has a bleed fitting installed in the outer race and requires modification of the previous trigger P/N 89004A5 or a new trigger P/N 89004A7 to provide clearance for the bleed fitting.

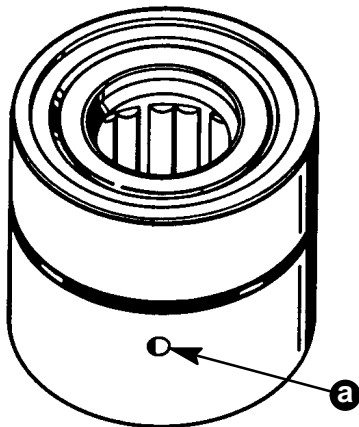

51473

a - Bleed Hole Between Upper and Lower Rollers

**FIGURE 1. PREVIOUS BEARING P/N 31-814409A1**

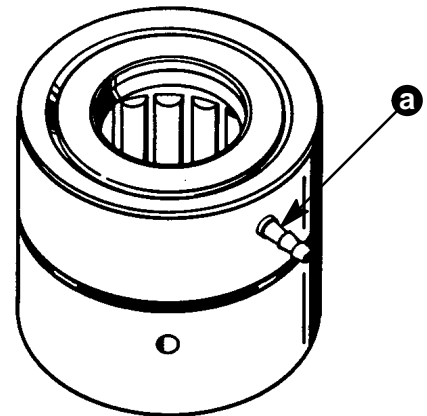

51473

a - Bleed Fitting Above Both Rows of Rollers

**FIGURE 2. NEW BEARING P/N 31-816773A1**

### ASSEMBLIES SHIPPED WITH NEW UPPER CRANKSHAFT BEARING

#### 250 MODEL

Cylinder Block	P/N 880-9550A14
Powerhead Assy.	P/N 92040A89

#### 275 MODEL

Cylinder Block	P/N 880-9550A33
Powerhead Assy.	P/N 19398A93

**TRIGGER MODIFICATION:**

Carefully remove material 1-3/8 inches (35mm) wide and even with the flat surface to allow clearance for bleed fitting. Round corners with sand paper.

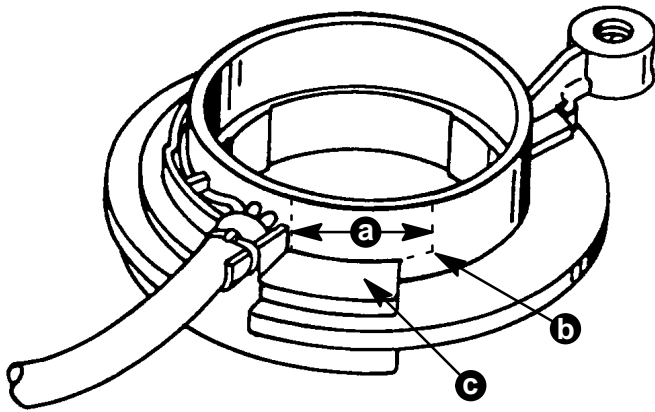

51905

- a - 1-3/8 inch (35mm)
- b - Remove Material
- c - Flat Surface

**FIGURE 3. PREVIOUS TRIGGER P/N 89004A5**

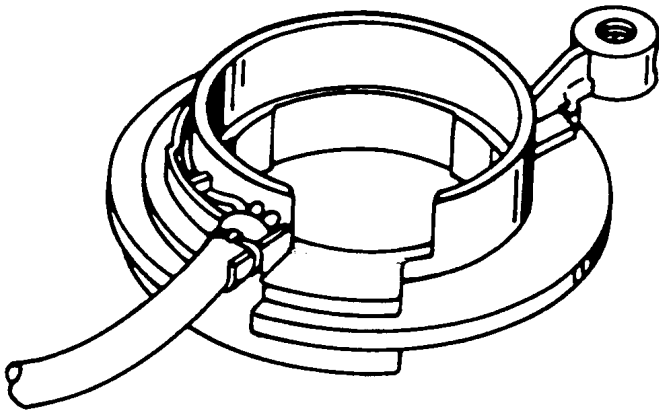

51905

**FIGURE 4. NEW TRIGGER P/N 89004A7**  
Previous trigger supersedes to new trigger.  
P/N 89004A5 Superseded to: P/N 98004A7

**REMINDER:**

When servicing a 250 or 275 with the new upper crankshaft bearing with the bleed fitting, the bleed line sta-strap locking tab must be turned towards the rear of the engine to provide clearance for the trigger arm (Figure 5).

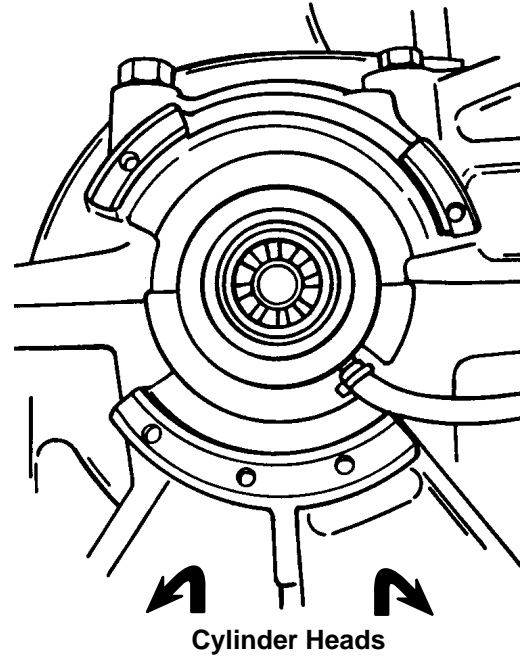

51473

- a - Sta-Strap Locking Tab

**FIGURE 5. TOP VIEW OF CYLINDER BLOCK**

This information will be added to the installation instructions packed with the service assemblies.

**WARRANTY:**

The new upper crankshaft bearing is offered as a product improvement and modifying or replacing the trigger is not covered by warranty.