



- A. Gasohol in MerCruiser Engines
- B. Approach Angle to Valve Seat in Cylinder Head -  
MCM/MIE 470 and MCM 485 Engines

---

CIRCULATE TO:  
SERVICE MANAGER  
PARTS MANAGER  
MECHANICS

## **A. GASOHOL IN MERCUISER ENGINES**

While gasohol (10% ethyl alcohol in lead-free gasoline) and other alcohol/gasoline blends used abroad are giving good service in cars, special precautions must be taken for use in MerCruiser-powered boats.

While Mercury Marine does not recommend gasohol for MerCruiser engines, it can be used. Tests to date reveal that it has no major effect on the rubber and neoprene fuel system parts.

Fuels containing alcohol have a tendency to absorb moisture slowly from the air. At first this moisture will remain in solution, but once the water content of the fuel has built up to somewhere around 1%, it will separate out, bringing the alcohol with it. This alcohol-water mixture settles at the bottom of the fuel tank and MerCruiser engines will not run on it. Before the engine can be restarted, it is necessary to remove the separated layer, flush out the fuel system with clean fuel and usually, remove and dry the spark plugs.

In cars, fuels containing alcohol normally are burnt before they can absorb enough moisture to cause trouble, but boats often sit idle long enough for separation to take place.

When operating a MerCruiser engine on gasohol, storage of gasohol in the fuel tank for periods of more than a few days must be avoided in a high humidity climate.

In such conditions, either drain the fuel tank and idle the engine until the carburetor runs dry, or run the tank nearly empty and refill with fresh fuel prior to the next use. If changing to straight gasoline, the engine then should be run long enough to purge the gasohol from the carburetor before shutting down.

The use of gasohol in MerCruiser four-cycle engines, that can run on lead-free fuel, is satisfactory, as it is in most automobiles, except for the risk of separation when fuel is stored in the tanks. Those MerCruiser engines, that were built in 1974 and prior years, however, required leaded gasoline. When gasohol is used in these (prior to 1975) engines, a minimum of one tank-full of leaded gasoline must be used after each four tank-fulls of gasohol.

## **B. APPROACH ANGLE TO VALVE SEAT IN CYLINDER HEAD - MCM/MIE 470 and MCM 485 ENGINES**

After valve seat in cylinder head has been refaced, recheck seat width. If seat width exceeds maximum limit, remove enough stock from top edge and/or bottom edge of seat to reduce width to specifications. Refer to the following chart for correct angles to be used on the different surfaces.

Model		Seat Width	Seat Angle	Top Edge (Approach Angle)	Bottom Edge
4	Intake	.060" - .080"	45°	20°	60°
7	Exhaust			30°	
4	Intake	.060" - .080"	30°	15°	60°
8	Exhaust		45°	30°	

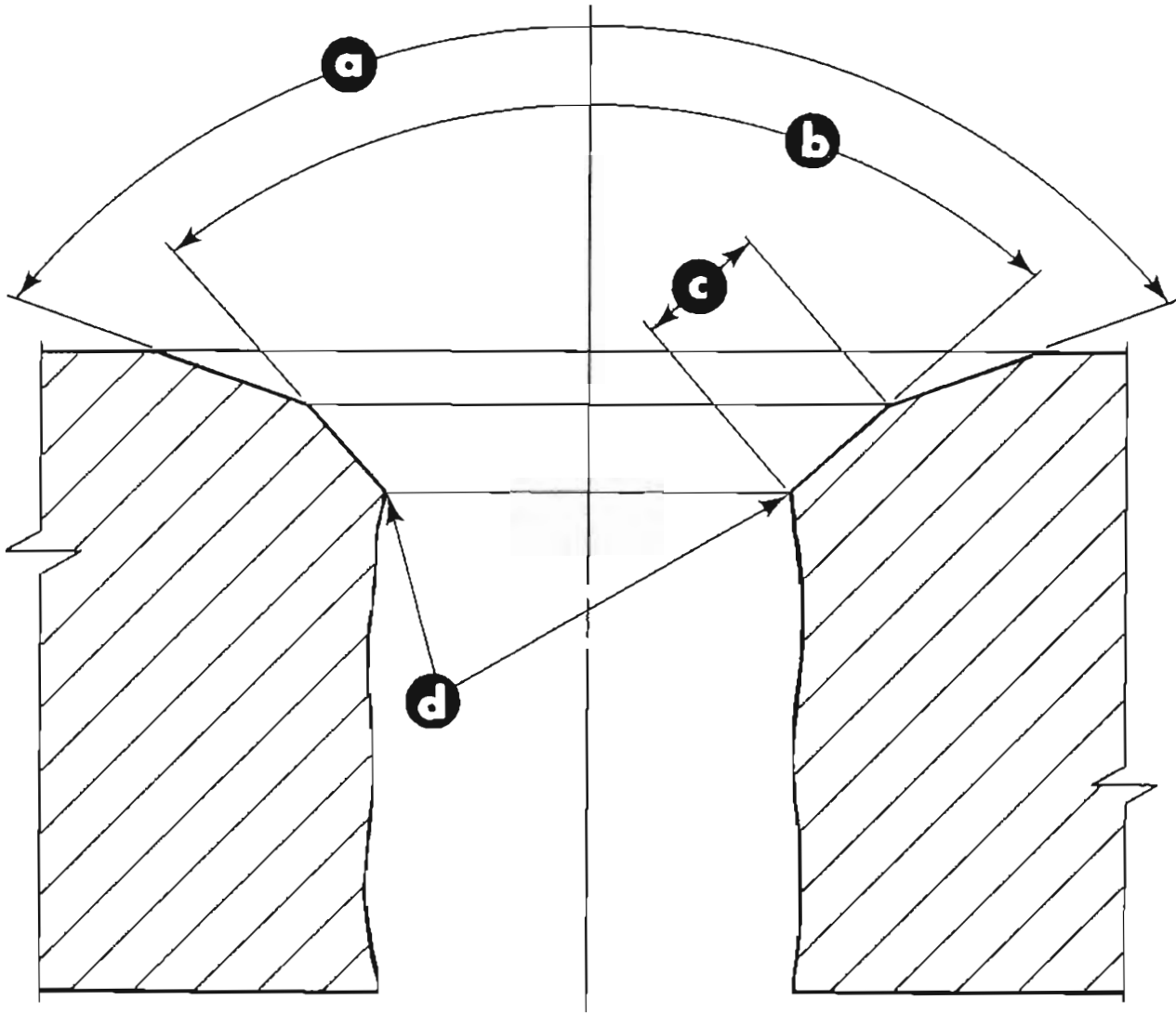

- a - Top Edge "Approach Angle"
- b - Seat Angle
- c - Seat Width
- d - Bottom Edge

**Figure 1. Valve Seat In Cylinder Head**