

TO: SERVICE MANAGER TECHNICIANS
PARTS MANAGER

No. 89-12

1988 vs. 1989 Bravo Drive Unit and Transom Assembly Interchangeability

To use a 1988 Bravo Drive Unit with a 1989 Transom Assembly the following must be done:

1. Disconnect oil reservoir hose (a) from fitting (b) on gimbal housing shown in Figure 1.
2. Cap off hose fitting (b) using cap (d) Part Number 94835 (ordered separately).
3. Remove oil reservoir (c) from bracket on transom.

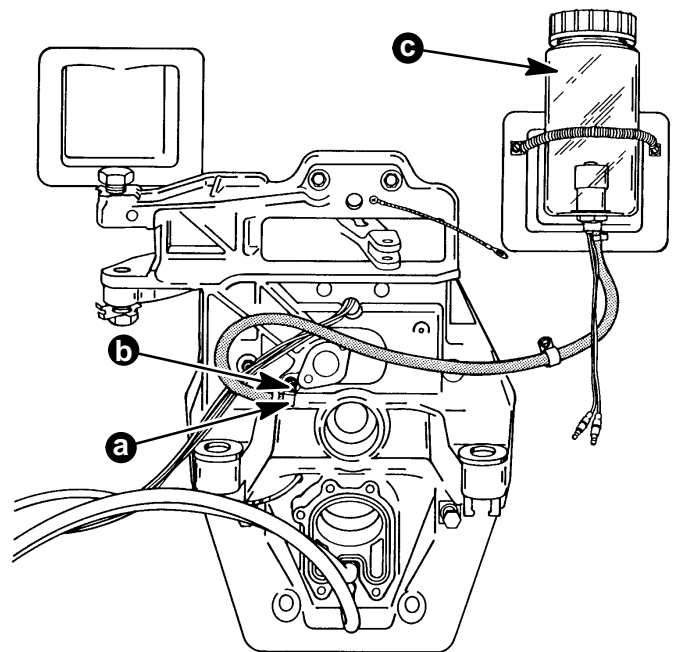
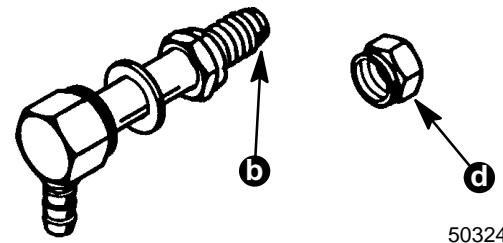
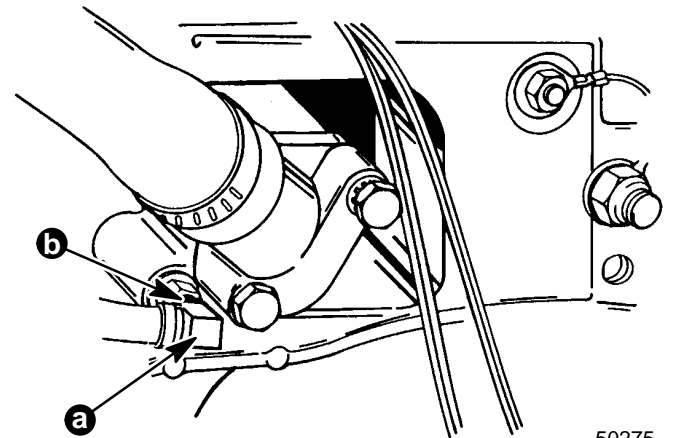

1989

- a - Oil Hose Connector
- b - Connector Fitting
- c - Reservoir Bottle
- d - Cap

Figure 1.

4. There were two different casting configurations in 1988 for both the drive shaft housing and the transom plate bell housing as shown in Figure 2 and 3. The differences are circled on each drawing. Later 1988 units affected by the differences are in the following serial number group (OC552726 thru OC552839).

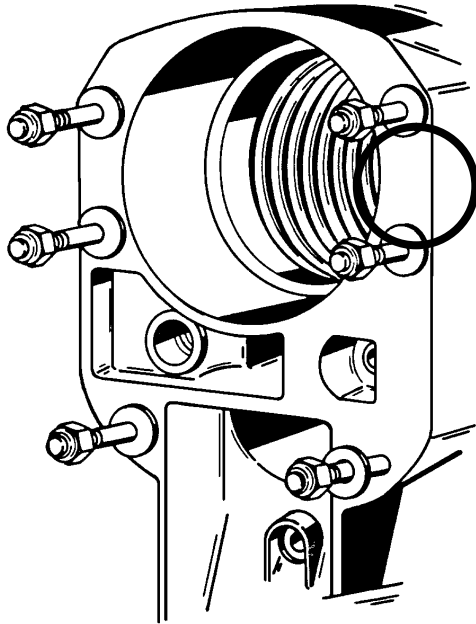

Early 1988

22081

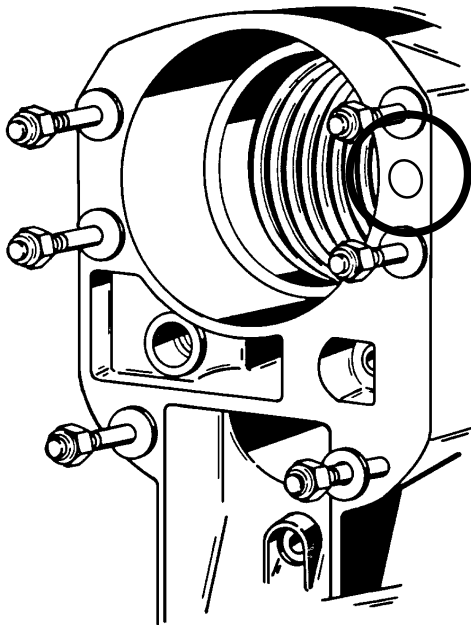

Late 1988

50322A

Figure 2.

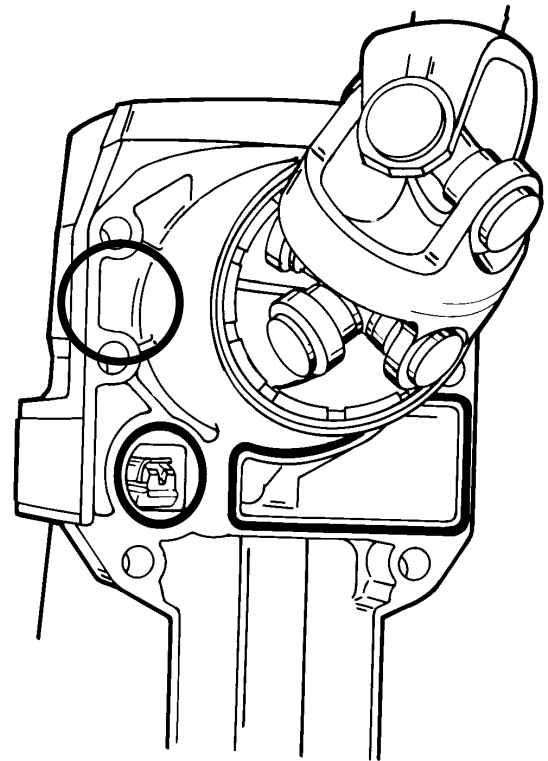

Early 1988

22031

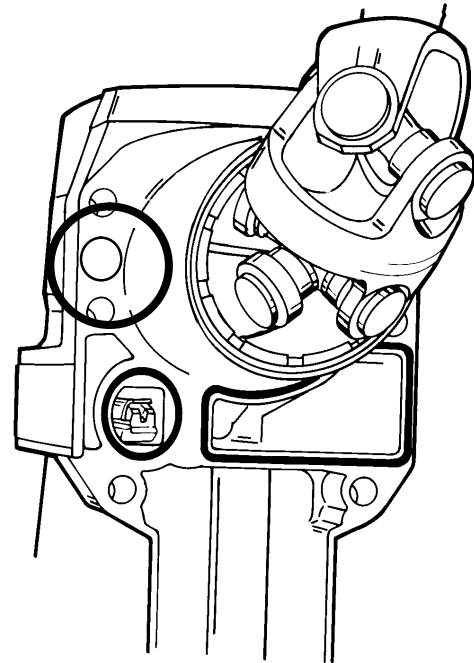

Late 1988

50356A

Figure 3.

To use a 1989 Bravo Drive on a 1988 Transom Plate Assembly the following procedure must be followed:

1. Fill in the oil seal at the check valve (Figure 4) with Quicksilver 2-4-C Marine Lubricant until flush with the surface of the drive shaft housing to prevent the possibility of corrosion from salt water.

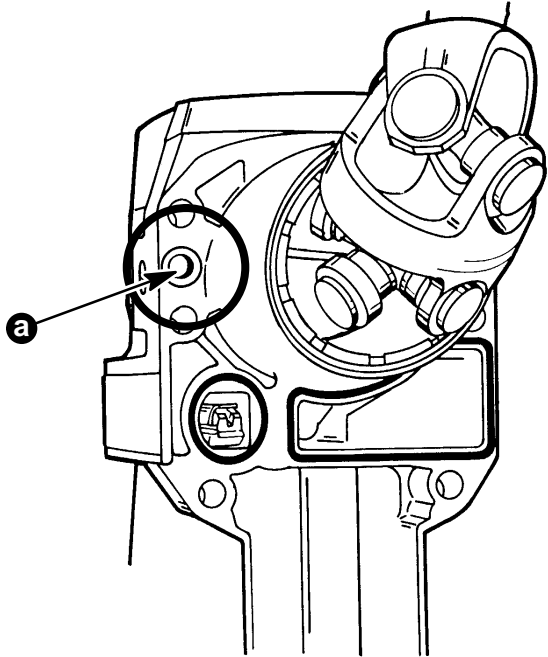

50356A

1989

a - Oil Seal

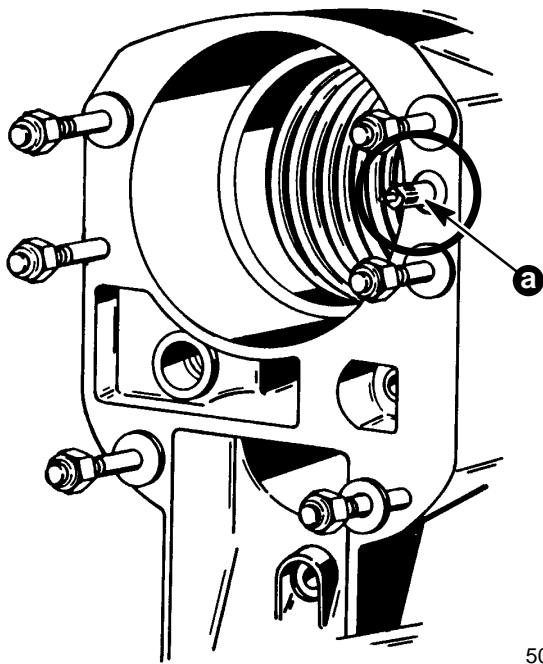

50322

1989

a - Check Valve
Figure 4.