

TO: SERVICE MANAGER MECHANICS
PARTS MANAGER

Revised
3-3-92

No. 91-20

A. BRAVO DRIVE UNIT/HOUSING COMPARISON AND IDENTIFICATION

Models

MCM 5.7L/7.4L/454Mag/502Mag/HP465/HP525SC/D183 Turbo/D219 Turbo/D254 Turbo

Changes

The latest production and service replacement housings will have an internal casting change to allow for an oil recirculation system on all 1991 and newer Bravo drive units, both Bravo one and Bravo Two models. The oil recirculation system is unique in that it causes the oil to flow from the lower gear case up through the drive-shaft housing to the universal joint pinion gear bearing set. Oil also pumps up into the top cover and returns to the lower gear case from the back side of the drive shaft housing, through the lower drive shaft needle bearing to the gear case. Besides improving lubrication this oil movement helps the drive unit run cooler.

Identification

1. DRIVE SHAFT HOUSING:

The upper drive shaft housing can be identified by looking at the number that is cast into the exhaust cavity face on the front of the housing as shown in the following illustrations.

2. GEAR HOUSING:

The lower gear case housing can be identified by looking at the number that is cast into the cavity in front of the trim tab screw on the top inside surface of the housing.

Drive Shaft Housing

When ordering an empty replacement upper drive shaft housing or an upper drive shaft housing complete look at the exhaust cavity in the front of the housing as shown in the drawings on the following pages for the casting numbers to reference the following information.

On the early style Bravo One and Bravo Two drive shaft housings you will find casting numbers (1589-8867 C) or (1589-8867 C2) or (1589-8867 C3). [Figure 1-2.] The proper service replacement number for an empty housing is (1589-8868A15) this housing will have the letter (S) machined into the housing in the exhaust cavity just above the casting number. [Figure 3-4.]

When ordering a complete upper drive housing assembly with the gears and bearings etc. already installed. Order the following part number (1589-8868A14) for a (1.50:1) Bravo One and a (2.00:1) Bravo Two or a (1589-8868A21) for a (1.36:1) Bravo One and a (1.81:1) Bravo Two. These complete assemblies will also have the letter (S) machined into the housing just above the (1589-8867) casting number in the exhaust cavity.

On the 1991 and newer drive shaft housings the casting number in the exhaust cavity will be (1589-8867 C5) only. [Figure 5-6.]

The proper service replacement number for an empty housing is (1589-8868A25). When ordering a complete upper housing assembly with the gears and bearings and etc. already installed. Order the following part number (1589-8868A27) for a (1.50:1) Bravo One and a (2.00:1) Bravo Two of a (1589-8868A29) for a (1.36:1) Bravo One and a (1.81:1) Bravo Two.

Gear Housing

If ordering an empty gear housing or a gear housing complete look into the cavity just in front of the trim tab screw up inside of the gear case as shown in the drawings on the following pages for the casting numbers to reference the following information.

On early style 1990 and prior Bravo One gear housings the casting numbers will be (1656-8865C) or (1656-8865C1) [Figure 7-8]. When ordering a service replacement housing only [Figure 9-10]. The correct part number to order is (1656-8866A11).

If ordering a complete service gear case assembly that includes all the gears/bearings/and shafts the following part number must be ordered (1656-8866A10). [Figure 9-10.]

On all 1991 and newer Bravo One empty gear housings the casting number will be (1656-8865C2) [Figure 11-12]. When ordering an empty housing only the part number is (1656-8866A17). When ordering a gear housing assembly complete including the gears/bearings and shafts the following part number must be ordered (1656-8866A15). [Figure 11-12.]

On early style 1990 and prior Bravo Two gear housings the casting numbers will be (1641-8293C) or (1641-8293C1) [Figure 13-14]. When ordering a service replacement housing only. The correct part number to order for the (1641-8293C) housing only is (1641-8294A8). The correct part number for the (1641-8293C1) housing only is (1641-8294A9).

If ordering a complete service gear case assembly that includes all the gears/bearings/and shafts for casting number (1641-8293C) or (1641-8293C1) the following part number must be ordered (1641-8294A7). [Figure 15-16.]

On all 1991 and newer Bravo Two empty gear housings the casting number will be (1641-8293C2)). When ordering a gear housing assembly complete including the gears/bearings and shafts the following part number must be ordered (1641-8294A14). [Figure 17-18.]

1990 and Prior Drive Shaft Housing

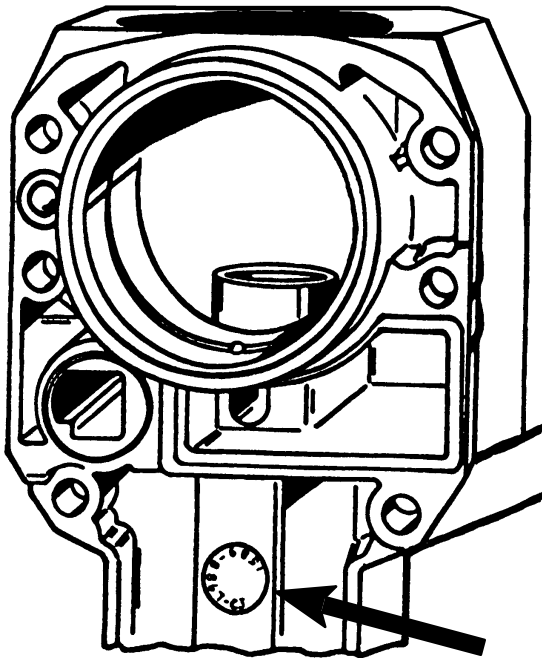

71224

Look in the area indicated by the arrow for the casting number.
The letters C/CZ/C3 are at the end of the casting number.

Figure 1.

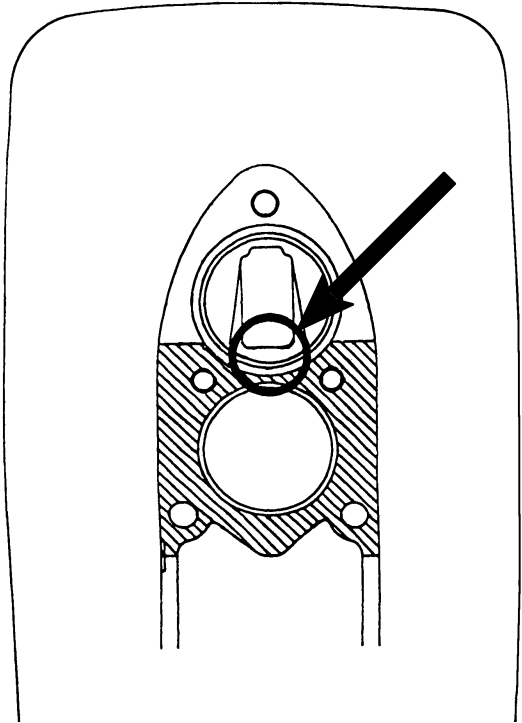

71187

The circled area on the housing indicated with an arrow, indicates an older style housing.

Figure 2.

Service Replacement for 1990 and Prior

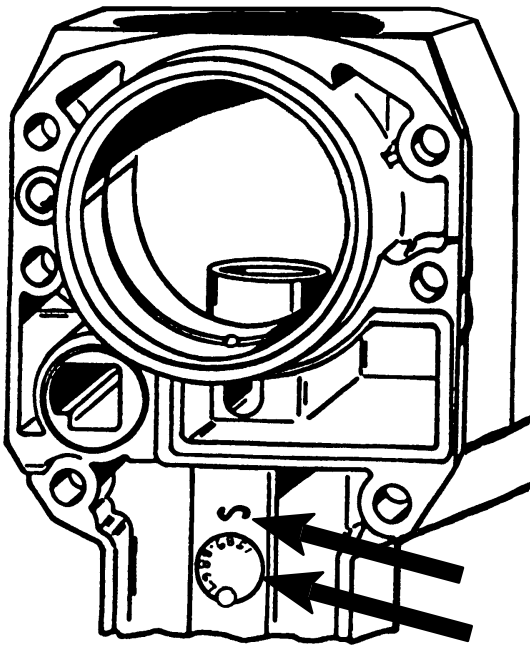

71225

Look in the area indicated by the arrows for the casting number. The service replacement housing will have the casting number only and the letter ["S"] machined into the housing just above the casting number, and will be the service replacement housing for the C/C2/and the C3 early style housings.

Figure 3.

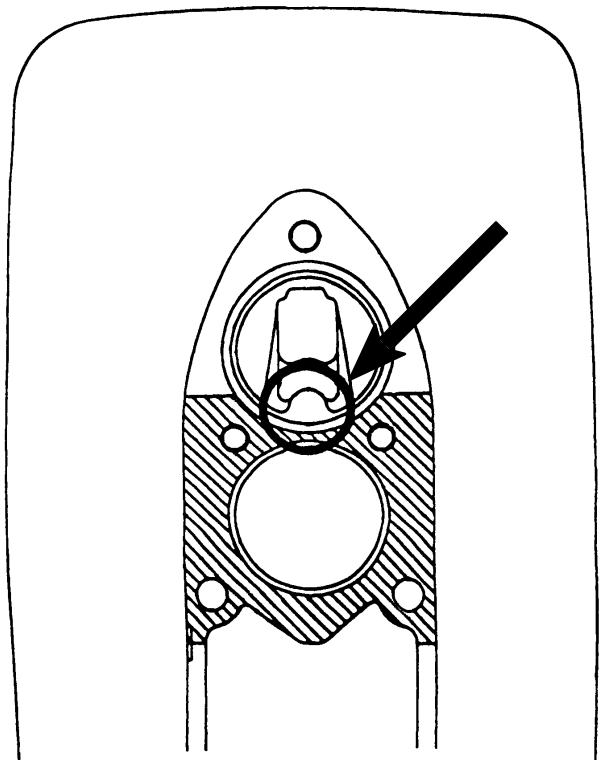

71189

The circled area on the housing indicated with an arrow shows where the change took place.

Figure 4.

1991 and Newer Drive Shaft Housing

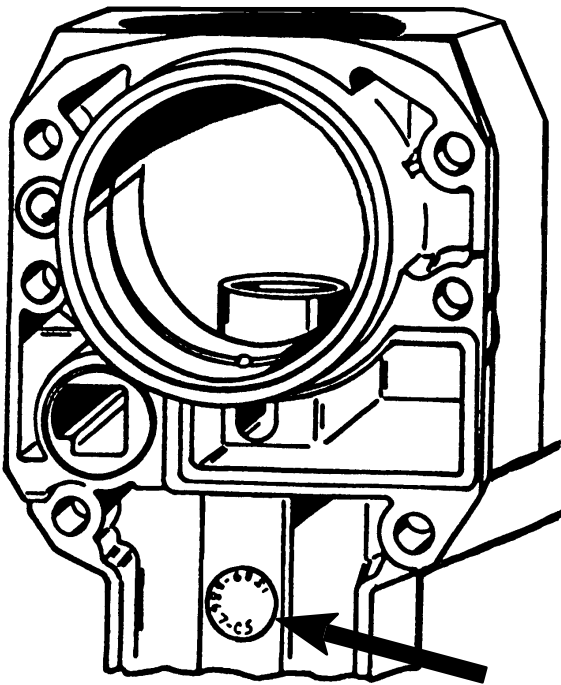

71226

Look in the area indicated by the arrow for the casting number, for the 1991 drive unit the casting number will have a C5 after the number.

Figure 5.

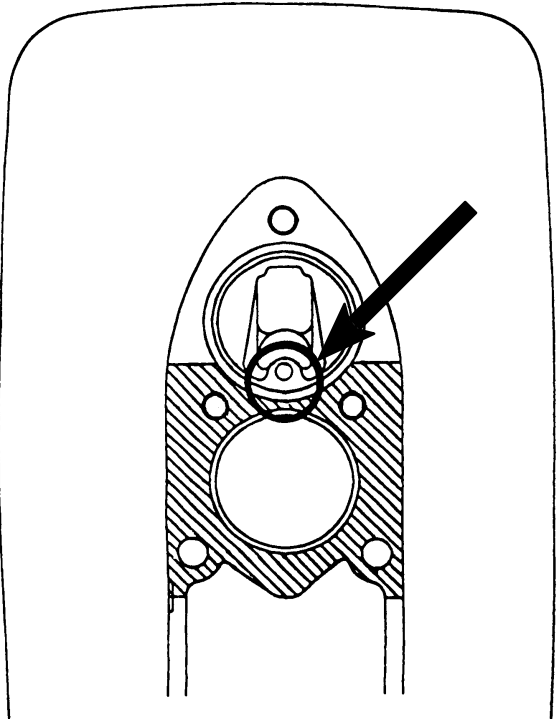

71188

The circled area on the housing indicated by an arrow shows where the change took place.

Figure 6.

Bravo One 1990 and Prior Gear Housing

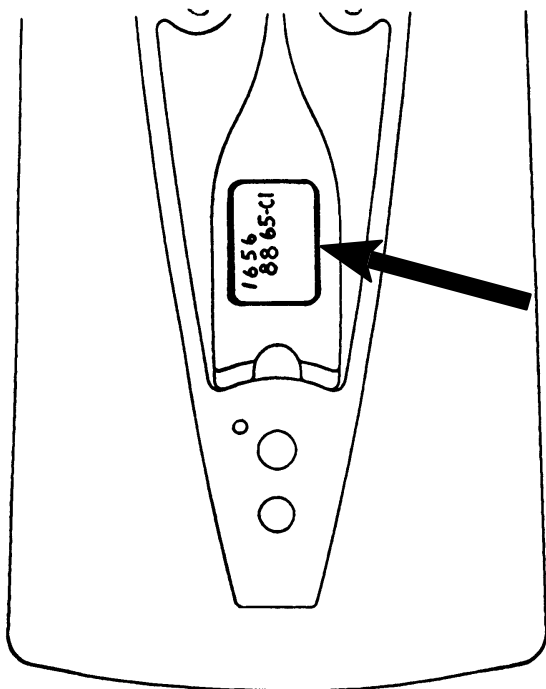

71190

Look in the area indicated by the arrow for the casting number. The letters after the casting number will be one of the following "C" or "C1".

Figure 7.

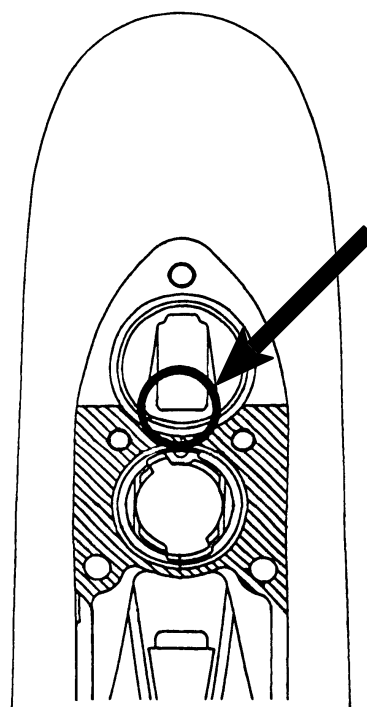

71191

The circled area on the housing indicated by an arrow shows the older style housing.

Figure 8.

Bravo One Service Replacement for 1990 and Prior

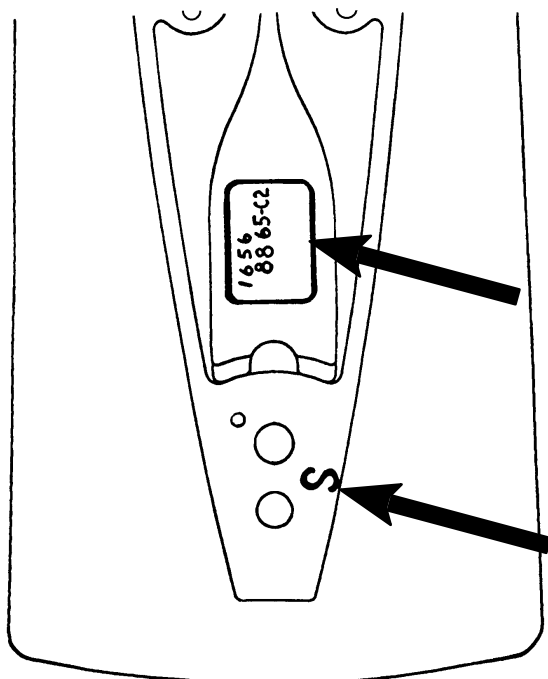

71193

Look in the area indicated by the arrow for the casting number. The letters will be "C2" also the housing will have a letter ["S"] machined into the mating surface of the gear case between the trim tab hole and the aft attaching bolt hole.

Figure 9.

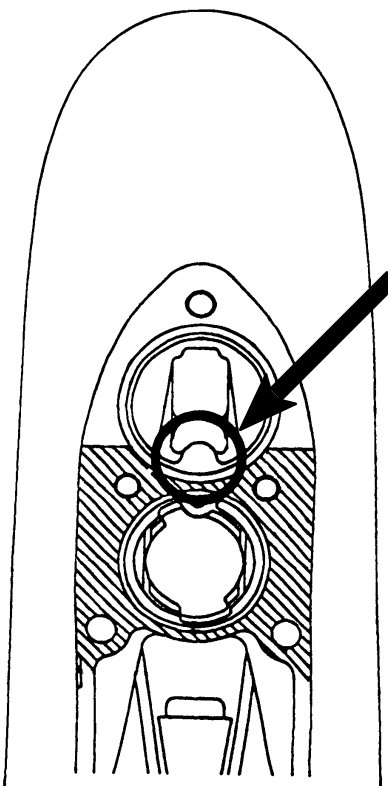

71192

The circled area on the housing indicated by an arrow shows where the change took place.

Figure 10.

Bravo One 1991 and Newer Gear Housing

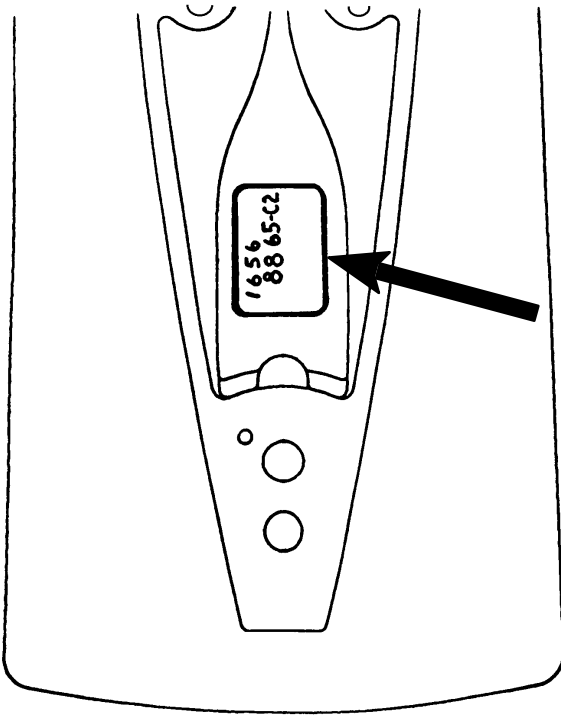

71194

Look in the area indicated by the arrow for the casting number. It will have a "C2" after the casting number.

Figure 11.

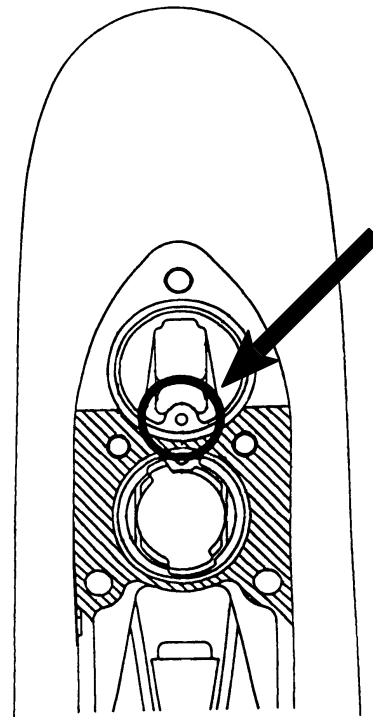

71195

The circled area on the housing indicated by an arrow shows where the change took place.

Figure 12.

Bravo Two 1990 and Prior Gear Housing

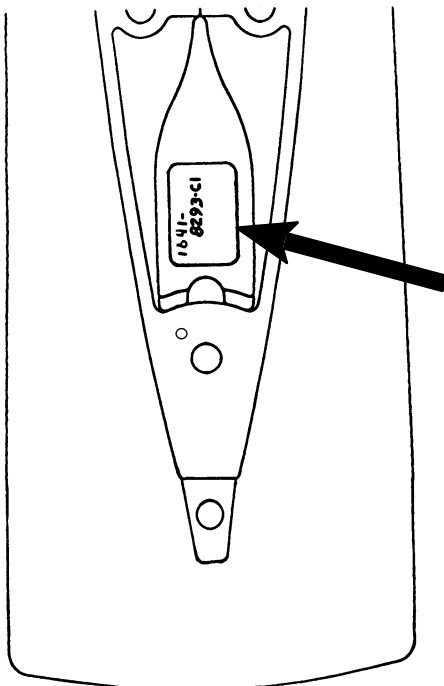

71196

Look in the area indicated by the arrow for the casting number. The letters after the casting number will be one of the following "C" or "C1".

Figure 13.

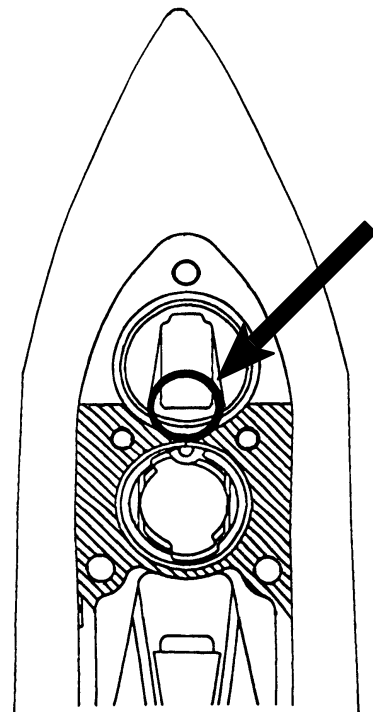

71197

The circled area on the housing indicated with an arrow shows the older style housing.

Figure 14.

Bravo Two Service Replacement for 1990 and Prior

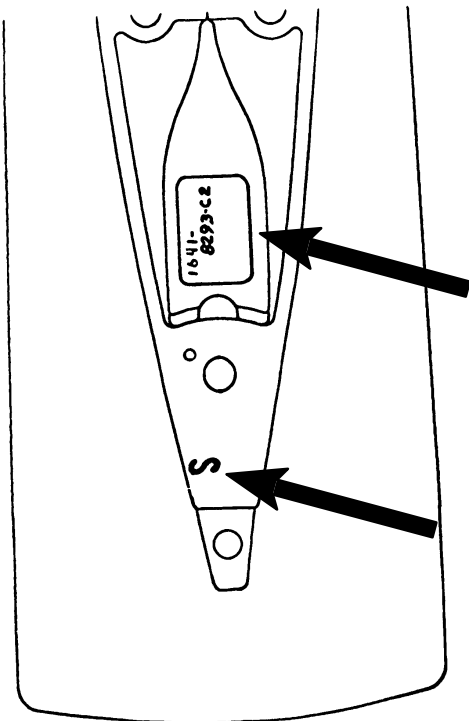

71198

Look in the area indicated by the arrow for the casting number. It will have a "C2" after the casting number, also the letter ["S"] will be machined into the mating surface of the gear case just behind the aft attaching bolt hole.

Figure 15.

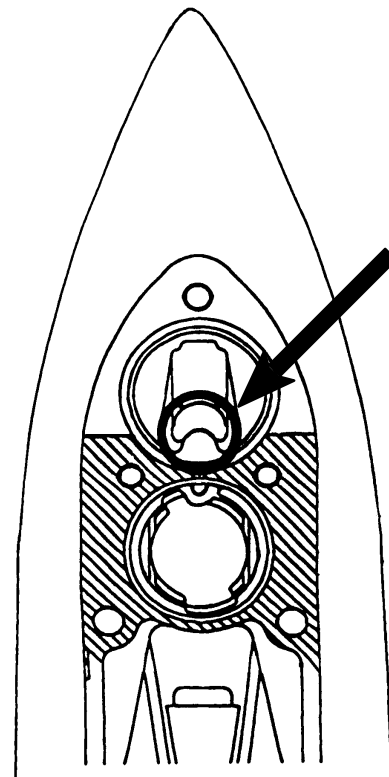

71199

The circled area on the housing indicated by an arrow shows where the change took place.

Figure 16.

Bravo Two 1991 and Newer Gear Housing

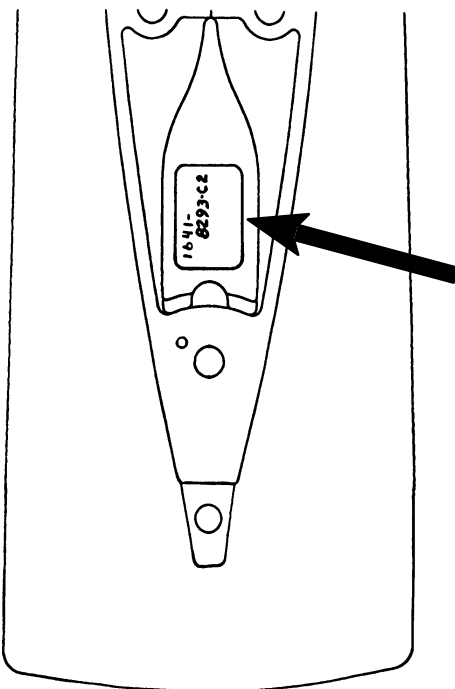

71200

Look in the area indicated by the arrow for the casting number. The Bravo Two for 1991 and newer will have a "C2" after the casting number.

Figure 17.

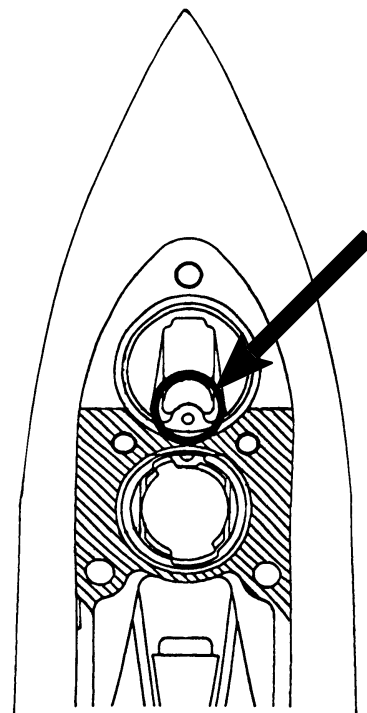

71201

The circled area on the housing indicated by an arrow shows where the change took place.

Figure 18.