



Service Bulletin

Outboard No. 2017-02R1

Circulate to: Sales Manager Accounting Service Manager Technician Parts Manager

200XS, 250XS, 300XS, and DSI Air Compressor Reed Failure

NOTICE
Revised June 2017. This bulletin supersedes the previous bulletin number 2017-02 March 2017.

Models Affected

Models Covered	Serial Number
200XS, 250XS, 300XS	1E052452–1E053251
OR	
JP OptiMax, 3.0L Diesel Spark Ignition (DSI)	1E052452–1E053251
OR	
200XS, 250XS, 300XS, and DSI service replacement air compressors, Julian date codes 14189 through 16246	N/A
OR	
Air compressors in dealer stock, Julian date codes 14189 through 16246	

Scope

Worldwide

Situation

The 2.5L and 3.0L OptiMax air compressor reeds may fail prematurely due to incorrect reed material. This may result in a no start condition, poor running quality, or engine stalling.

Correction

Identification

IMPORTANT: A white dot on the edge of the reed plate assembly indicates the reed plate assembly has been replaced. Do not rework a compressor with a white dot on the edge of the reed plate assembly.

Check the engine to confirm whether the air compressor is an affected unit. If no white dot is present and the engine serial number falls within the range specified at the top of this service bulletin, replace the reed plate assembly.

THE INFORMATION IN THIS DOCUMENT IS CONFIDENTIAL AND PROTECTED BY COPYRIGHT AND IS THE PROPERTY OF MERCURY MARINE.

This document is provided for the sole and exclusive use of the original recipient as prescribed by Mercury Marine and may not be distributed or copied, digitally or otherwise, without the prior written consent of Mercury Marine.

Inspect all in-stock replacement air compressors. If no white dot is present and the Julian date code falls between 14189 (July 8, 2014) and 16246 (September 2, 2016), inclusive, replace the reed plate assembly.

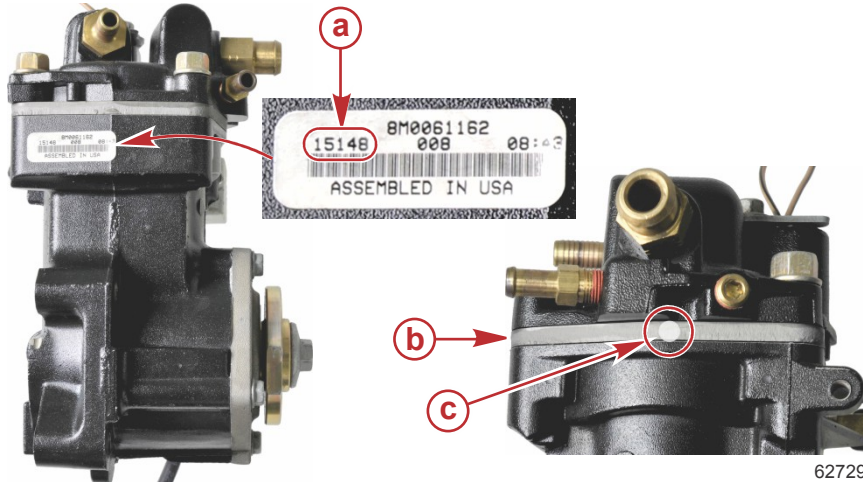

Air compressor

- a - Julian date code; codes 14189 through 16246 are affected
- b - Reed plate assembly
- c - White dot indicating that the reed plate assembly has been replaced and is not affected

Parts Required

Reed plate assembly, p/n 835088A10.

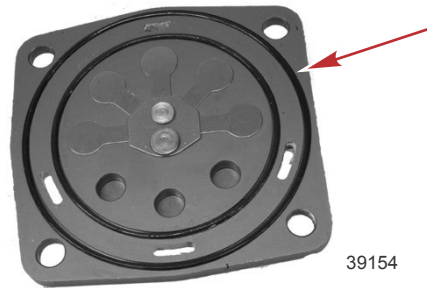

Reed plate assembly

Port Fuel Rail Disengagement (2.5L Only)

IMPORTANT: Do not remove the lower cowl. The fuel rail can be easily positioned out of the way without removing the cowl.

In order to access the lower left-hand screw on the air compressor cylinder head on 2.5L models, the port fuel rail must be temporarily disengaged and moved out of the way.

1. Disconnect the cylinder head temperature sensor harness connector.
2. Disconnect the compressor water inlet hose.

THE INFORMATION IN THIS DOCUMENT IS CONFIDENTIAL AND PROTECTED BY COPYRIGHT AND IS THE PROPERTY OF MERCURY MARINE.

This document is provided for the sole and exclusive use of the original recipient as prescribed by Mercury Marine and may not be distributed or copied, digitally or otherwise, without the prior written consent of Mercury Marine.

3. Remove the two fuel rail mounting nuts.

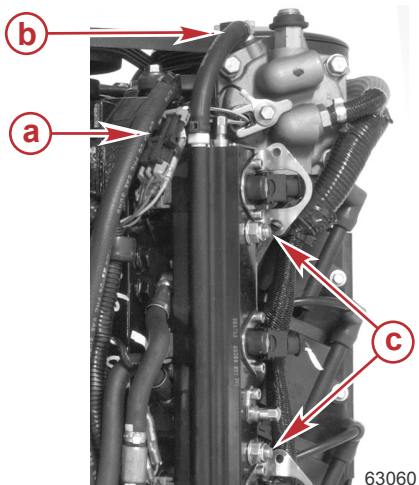

- a - Cylinder head temperature sensor harness connector
- b - Compressor water inlet hose
- c - Fuel rail mounting nuts (2)

4. Without removing the lower cowl, position the fuel rail out of the way, and complete the reed plate assembly replacement. Before putting the engine back into service, be certain to reconnect all items and tighten the fuel rail mounting nuts to the specified torque.

Description	Nm	lb-in.	lb-ft
Fuel rail mounting nuts (2)	44.7	-	33

Reed Plate Assembly Replacement

- To indicate that the rework procedure has been completed, mark the top edge of the replacement reed plate assembly with a white dot.



Reed plate assembly edge marked with a white dot

THE INFORMATION IN THIS DOCUMENT IS CONFIDENTIAL AND PROTECTED BY COPYRIGHT AND IS THE PROPERTY OF MERCURY MARINE.

This document is provided for the sole and exclusive use of the original recipient as prescribed by Mercury Marine and may not be distributed or copied, digitally or otherwise, without the prior written consent of Mercury Marine.

- When installing the cylinder head, tighten the four cylinder head screws in a cross pattern to the specified torque.

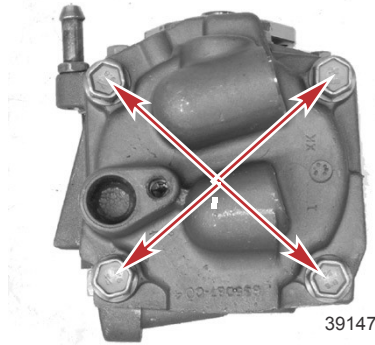

Description	Nm	lb-in.	lb-ft
Cylinder head screws	27	-	20

- After the replacement is complete, test the installation:
 - For customer-owned engines, run the engine with water supplied to the cooling system. Verify the fuel and air pressures. Check for leaks.
 - For engines in dealer stock, verify the fuel and air pressures during the Predelivery Inspection (PDI).

Owner Notification

A letter will be sent to every registered owner of an affected OptiMax V6 engine. The letter will reference Mercury Racing Outboard Service Bulletin 2017-02 and will advise the owner to contact their selling dealer or a Mercury authorized dealer for inspection or repair. A copy of the customer letter is included with this service bulletin for your reference.

Warranty

United States and Canada: If the engine is within the warranty period, submit a warranty claim through your normal warranty processing channel. Be sure to reference Mercury Racing Outboard Service Bulletin 2017-02 in the claim text. For each engine serial number:

	Labor	Code
Reed assembly removal and replacement (2.5L or 3.0L):	0.3 hr	NJC
Port fuel rail temporary disengagement (2.5L only):	0.3 hr	NJC
Testing (engine is customer owned):	0.5 hr	NJC
Testing (engine is in dealer stock):	0.2 hr	NJC

Outside the United States and Canada: Follow the instructions issued by your local office or distributor.

THE INFORMATION IN THIS DOCUMENT IS CONFIDENTIAL AND PROTECTED BY COPYRIGHT AND IS THE PROPERTY OF MERCURY MARINE.

This document is provided for the sole and exclusive use of the original recipient as prescribed by Mercury Marine and may not be distributed or copied, digitally or otherwise, without the prior written consent of Mercury Marine.

Dear Mercury Marine Customer,

Thank you for your patronage. We at Mercury are dedicated to providing superior product of outstanding quality and reliability. As part of our continuing efforts to exceed our customer's expectations, we have determined that certain unscheduled service to your registered product may be necessary.

What is the Condition?

We have identified a potential issue with the Mercury Racing Outboard engine on your vessel. You may experience a no start condition, a rough running engine, or engine stalling. If left unattended, these effects could lead to unpleasant boating experiences and your eventual dissatisfaction with Mercury Marine. We find these scenarios unacceptable.

What Will We at Mercury Do?

We have provided instructions to our authorized dealers for this service. The required service will be performed at NO COST to you.

What Should You Do?

Contact your authorized Mercury dealer to schedule a service appointment. Be sure to mention Mercury Racing Outboard Service Bulletin 2017-02.

Please present this notice to your authorized Mercury dealer at the time of service.

If you have any questions or no longer own this Mercury product, please contact Mercury Marine Customer Assistance, at 1-920-929-5040, between 7:30 AM and 4:30 PM, Central Time.

We have sent this notice in the interest of your continued satisfaction with our product. We sincerely regret any inconvenience this may cause you.

Thank you for boating with Mercury Marine.

Mercury Marine Customer Service