

## Official Notification - Federal Boat Safety Act Sport Jet 90

### 1993 and 1994 SPORT JET 90

#### GROUP #1

0E021000 THRU 0E038385 (PUMP UNIT)

#### GROUP #2

0E057883 THRU 0E079055 (PUMP UNIT)

#### GROUP #3 (BOAT BUILDER CAMPAIGN)

0E009675 THRU 0E090228 (POWERHEAD)

Excludes the Sport Jet in Bayliner, Pro-Line and Donzi boats.

Sport Jet 90 units have two serial numbers. Please note that the serial number at the powerhead (a) is not the same as the pump (b). Sport Jet 90 units may have a field campaign involving both the powerhead and the pump.

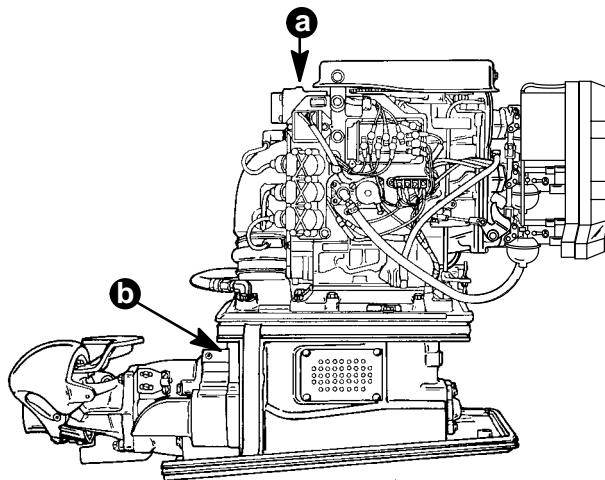

a - Power Head Serial Number  
b - Jet Pump Serial Number

Listed are the items by the three groups which are involved in a field campaign under the guidelines established by the Federal Boat Safety Act. Rework Sport Jets in stock per these instructions.

#### GROUP #1

#### LOCKING TAB - SHIFT CABLE CLAMP

S/N 0E021000 THRU 0E038385

We have some reports of the shift cable clamp screws loosening. This condition can result in loss of shift control.

The following are the procedures to rectify this condition.

1. Install a tab lock, p/n 14-820601, as shown in the figure below with radius portion (b) of the tab lock towards the reverse gate.
2. Torque screws (a) to 50 lb. in. (5.65 N-m).
3. Bend tabs (c) over flats of the screw head.

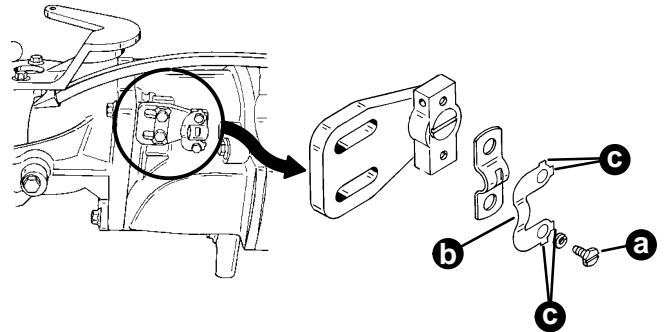

a - Screw (2)  
b - Tab Lock- Positioned Toward Reverse Gate  
c - Locking Tabs

#### GROUP #2

#### PIVOT BOLT - REVERSE GATE

S/N 0E057883 THRU 0E079055

Loose reverse gate pivot bolts have been reported on some pumps. This condition can lead to loss of shift control.

The following are the procedures to rectify this condition:

1. Remove three pivot bolts (a) as shown in the figure following.

- Apply Loctite #271 (p/n 92-32609-1) to threads of the pivot bolts.
- Install pivot bolts (a) and torque to 25 lb. ft. (33.89 N·m).

Some jet pumps have already been reworked at the factory. They can be identified by a WHITE dot painted next to the serial number decal on the pump unit and require no further action.

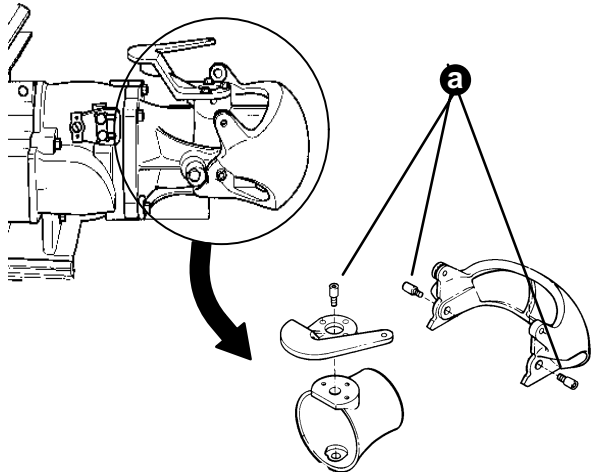

a - Pivot Bolts (3)

**GROUP #3  
BOOT - STARTER SOLENOID**

**S/N 0E009675 THRU 0E090228**

To be Completed with Either Group #1 or #2.

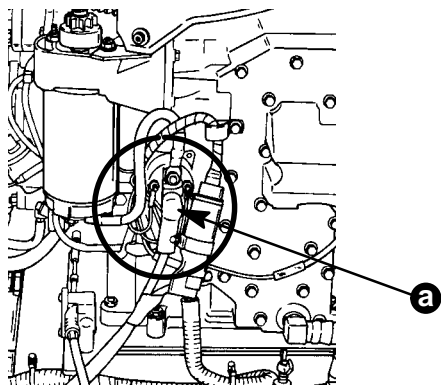

a - Boot, Positive Battery Terminal

The U.S. Coast Guard recently cited two boat builders who were in violation of regulation #33 CFR 183.445 (b) which requires that the “positive” battery cable connection at the starter solenoid terminal be protected by either a boot (a) or protective shield.

Mercury Marine is not responsible to conduct this field campaign. It is the responsibility of the boat builder to notify the appropriate dealers and consumers.

**⚠ WARNING**

**To prevent possible electrical shock, fire or explosion disconnect the battery leads at the battery before removing the positive battery terminal from the starter solenoid.**

For the convenience of all parties (the consumer, dealer and boat builder), inspect the starter solenoid terminal connection with the “positive” battery cable to see if it is protected with a boot. If it is not, order the boot (p/n 85-79695) and install on the terminal connection of the “positive” battery cable and terminal of the starter solenoid.

**NOTE: Please submit warranty claim for the solenoid boot to the boat builder.**

**OWNER NOTIFICATION (US AND CANADA)**

A combination letter/claim will be sent to every registered owner of the affected unit within the listed serial number ranges. The letter will advise the owner to return their boat to the selling dealer or an authorized servicing dealer to have the rework performed. A copy of the letter/claim is attached to this service bulletin.

**WARRANTY:**

Complete the warranty claim listing:

- Jet Pump serial number
- .5 hours labor
- Parts used
- Warranty labor code: NJC
- Failure code: 827-40 (Pivot Bolts)

OR

849-40 (Locking Tab)

Complete and return the pre-printed warranty claim form sent to the customer.

**INTERNATIONAL**

Follow instructions issued by Marine Power International office or by your distributor.