

TO: SERVICE MANAGER MECHANICS
 PARTS MANAGER

No. 97-8

H.P. 900 SC Specifications - Serial No. 0K000856 & Up

Table of Contents

Tune-Up	1
Electrical Specifications	2
Carburetor Specifications	3
Internal Engine Specifications	3
Torque Specifications	5
Wiring Diagram 900 SC	7
Cooling System Water Flow Diagram 900 SC	8

TUNE-UP

Horsepower (Kilowatts)	900 (522)
Displacement (Liters)	542 CID (8.9 L)
Engine Type and Number of Cylinders	V8
Bore	4.44 in. (114.4mm)
Stroke	4.375 in. (114.4mm)
Compression Ratio	8.03:1
Compression Pressure	150 psi (1035 kPa)
Ignition	Thunderbolt V
Spark Plug Type-P/N	Champion N63YD
Spark Plug Gap	.025 in. (0.6 mm)
Maximum Advance @ 5000 RPM	32° BTDC
Maximum RPM at Wide-Open-Throttle	5600-6000 RPM
Idle RPM in Forward Gear	1150-1300 RPM
Firing Order	1-8-4-3-6-5-7-2
Valve Lash (Int. & Exh.)	Cold: 0.016 (0.4mm) Hot: 0.020 (0.5mm)
Fuel Required	92 Octane {(R+M)÷2} or 98 RON (NOTE 1)
Fuel Pump Pressure	5-7 psi (34-48 kPa)
Electrical System	12-Volt Negative Ground
Alternator Rating	55 Amperes
Supercharger Boost	7-8 psi (48-55 kPa)
Recommended Battery Rating	Min. 550 CCA

continued on next page

TUNE-UP (CONT.)

Crankcase Oil Capacity with New Filter	11 Qts. (10.5 Liters) (NOTE 2)
Oil Pressure at 2000 RPM	30 - 70 psi (207-483 kPa)
Seawater Cooling System	20 U.S. Qts. (19L) (NOTE 3)
Transmission Fluid Type F Capacity	2 U.S. Qts. (1.9L) (NOTE 2)
MC Slx Stern Drive Unit Oil Capacity	20 U.S. Qts. (19L) (NOTE 4)

NOTE: (1) Without alcohol whenever possible.

NOTE: (2) Approximate, ALWAYS use dipstick to determine exact quantity of oil required.

NOTE: (3) Cooling System Capacity information is for winterization use only.

NOTE: (4) Refer to SSM drive manuals for capacities when using spacers.

Figure 1 L.H. Rotation

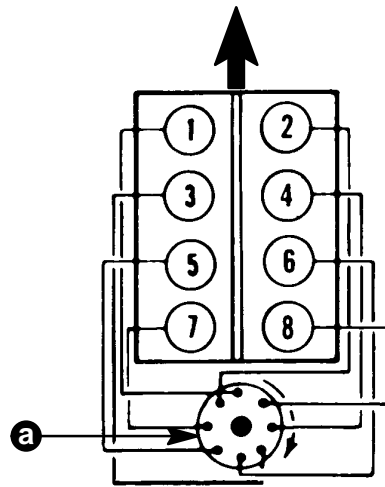

a - Firing Order: 1-8-4-3-6-5-7-2

ELECTRICAL SPECIFICATIONS

Ignition Specifications

Timing	32° BTDC @ 5000 RPM
Coil	Part No. 332-4895A8
Coil Primary Resistance (Ohms) Minimum	.010
Coil Primary Resistance (Ohms) Maximum	.015
Coil Secondary Resistance (Ohms)	575-725

Starter Motor Specifications

Mercury Marine Part No.		50-808011A3		
Delco Remy Part No.		19010615		
No Load Test				
Volts	Amps. (Min.)	Amps. (Max.)	RPM (Min.)	RPM (Max.)
10.6	60	100	6000	9200

CARBURETOR SPECIFICATIONS

Make (Model)	Holley (4500)
Mercury Part No.	12377A8
Float Adjustment	Bottom of Sight Plug Hole \pm 1/32" (.8 mm)
Primary Jets	No. 96
Secondary Jets	No. 98
Accelerator Pump	.015" (.4 mm)
Idle Mixture Screw Preliminary Setting	1-1/2 turns out

INTERNAL ENGINE SPECIFICATIONS

UNIT OF MEASUREMENT: in. (mm)

Cylinder Bore

Diameter	4.440 - 4.442 (112.776 - 112.826)	
Out of Round	Production	.001 (0.0254)
	Service	.002 (0.051)
Taper	Production	.0005 (0.0127)
	Service	.001 (0.025)

Piston: See Note

Clearance	Production & Service	.0055 - .0085 (0.1397 - 0.2159)
-----------	----------------------	---------------------------------

NOTE: Measure piston 1.300 in. (33.02 mm) down from lower oil ring groove and 90° from piston pin bore.

Piston Ring:

COMPRESSION RINGS

Groove Side Clearance		
Production	Top & 2nd	.0017 - .0032 (0.044 - 0.0814)
Service	Top & 2nd	.0027 - .0042 (0.0687 - 0.1068)
End Gap		
Service	Top	.033 - .035 (0.838 - 0.889)
	2nd	.029 - .031 (0.737 - 0.787)

OIL RINGS

Groove Side Clearance	
Production	.0005 - .0065 (0.0127 - 0.1651)
Service	.0015 - .0075 (0.0381 - 0.191)
End Gap	
Production	.015 - .055 (0.381 - 1.397)
Service	.025 - .065 (0.635 - 1.651)

Piston Pin: Free Floating

Diameter		.990 (25.146)
Clearance	Production	.0008 - .001 (0.0203 - 0.0254)
	Service	.001 - .0012 (0.0254 - 0.0305)
Fit to Rod		.0008 - .0012 (0.0203 - 0.0305)

Crankshaft: Kryptinite Crank

MAIN JOURNAL

Diameter	No. 1,2,3,4	2.748 - 2.749 (69.8195 - 69.8246)
	No. 5	2.745 - 2.748 (69.723 - 69.799)
Taper & Out of Round	Production	.0005 (0.0127)
	Service	.001 (0.0254)

CONNECTING ROD JOURNAL

Diameter		2.1980 - 2.1990 (55.8292 - 55.8546)
Taper & Out of Round	Production	.0005 (0.0127)
	Service	.001 (0.0254) max.

MAIN BEARING CLEARANCES

Production	No. 1,2,3,4	.0025 - .003 (0.0635 - 0.0762)
	No. 5	.0035 - .004 (0.0889 - 0.1016)
Service	No. 1,2,3,4	.0025 - .0035 (0.0635 - 0.0889)
	No. 5	.0035 - .0045 (0.0889 - 0.1143)
Crankshaft End Play		.007 - .010 (0.1778 - 0.2540)
Crankshaft Run Out		.0005 - .0015 (0.0127 - 0.0381)

ROD BEARING CLEARANCES

Rod Bearing Clearance	.0025 - .0035 (0.0635 - .0889)
Rod Side Clearance	.018 - .025 (.46 - .64)

Camshaft and Drive:

Lobe Lift ± .002 (0.051)	Intake	.395 (10.033)
	Exhaust	.395 (10.033)
Journal Diameter		1.948 - 1.949 (49.48 - 49.51)
Journal Out-of-Round		.001 (0.0254)
Camshaft Run-Out		.0015 (0.0381)
Timing Belt		Non Adjustable

Valve System:

Lifter Type	Solid Roller	
Rocker Arm Ratio	1.7:1	
Valve Lash (Int. & Exh.)	Cold: .016 (0.4) Hot: .020 (0.5)	
Face Angle (Int. & Exh.)	45°	
Seat Angle (Int. & Exh.)	45°	
Seat Run Out (Int. & Exh.)	.002 (0.0508)	
Seat Width	Intake	.080 (2.03)
	Exhaust	.080 (2.03)
Stem Clearance		
Production	Intake	.001 (0.0254)
	Exhaust	.0015 (0.0381)
Service	Intake	.002 (0.0508)
	Exhaust	.0025 (0.0635)
Valve Spring		
Free Length	2.440 (61.976)	
Pressure Lbs. @ Inches (mm) (See Note)	Closed @ 2.050 (52.07)	150 lbs. (203 Nm)
	Open @ 1.370 (34.7)	470 lbs. (637 Nm)
Installed Height	2.050 (52.07)	

NOTE: Test springs as a complete assembly with dampener.

Cylinder Head:

Gasket Surface Flatness	.002 (.050) in 6" (152) .005" (.127) Overall
-------------------------	--

Flywheel:

Run Out on Face Area	.008 (.20)
----------------------	------------

TORQUE SPECIFICATIONS

Camshaft Sprocket/Gear (NOTE 1)	25 lb.ft. (34 N·m)
Conn. Rod Cap (NOTE 2)	90 lb. ft. (109 N·m)
Crankcase Front Cover	80 lb. in. (9 N·m)
Cylinder Head (NOTE 3)	80 lb. ft. (109 N·m)
Distributor Clamp	15 lb. ft. (20 N·m)
Exhaust Manifold (Bolts)	25 lb. ft. (34 N·m)
Flywheel (NOTE 1)	90 lb. ft. (95 N·m)
Flywheel Drive Plate (NOTE 1)	45 lb. ft. (42 N·m)
Flywheel Housing	30 lb. ft. (41 N·m)
Intake Manifold	30 lb. ft. (41 N·m)

continued on next page

TORQUE SPECIFICATIONS (CONT.)

Main Bearing Cap All 19 of 6pt. Nuts (NOTE 2)	110 lb. ft. (149 N·m)
Main Bearing Cap (1) 12pt. Nut On #5 Main (NOTE 2)	95 lb. ft. (129 N·m)
Oil Pan to Crankcase (5/16-18)	165 lb. in. (19 N·m)
Oil Pan to Crankcase (1/4-20)	80 lb. in. (9 N·m)
Oil Pan Drain Plug	20 lb. ft. (27 N·m)
Oil Pump (NOTE 1)	70 lb. ft. (95 N·m)
Oil Pump Cover	80 lb. in. (9 N·m)
Rocker Arm Stud (NOTE 1)	70 lb. ft. (95 N·m)
Rocker Arm Cover	72 lb. in. (8.1 N·m)
Spark Plug	15 lb. ft. (20 N·m)
Torsional Damper	110 lb. ft. (149 N·m)
Water Inlet	30 lb. ft. (41 N·m)

NOTE: 1 Use Loctite 271 (P/N 92-32609-1) on threads.

NOTE: 2 Apply moly lube on washer and under bolt head as well as on the threads.

NOTE: 3 Apply oil under bolt head, and Teflon pipe thread sealant (like Loctite sealant #592) on threads.

WIRING DIAGRAM 900 SC

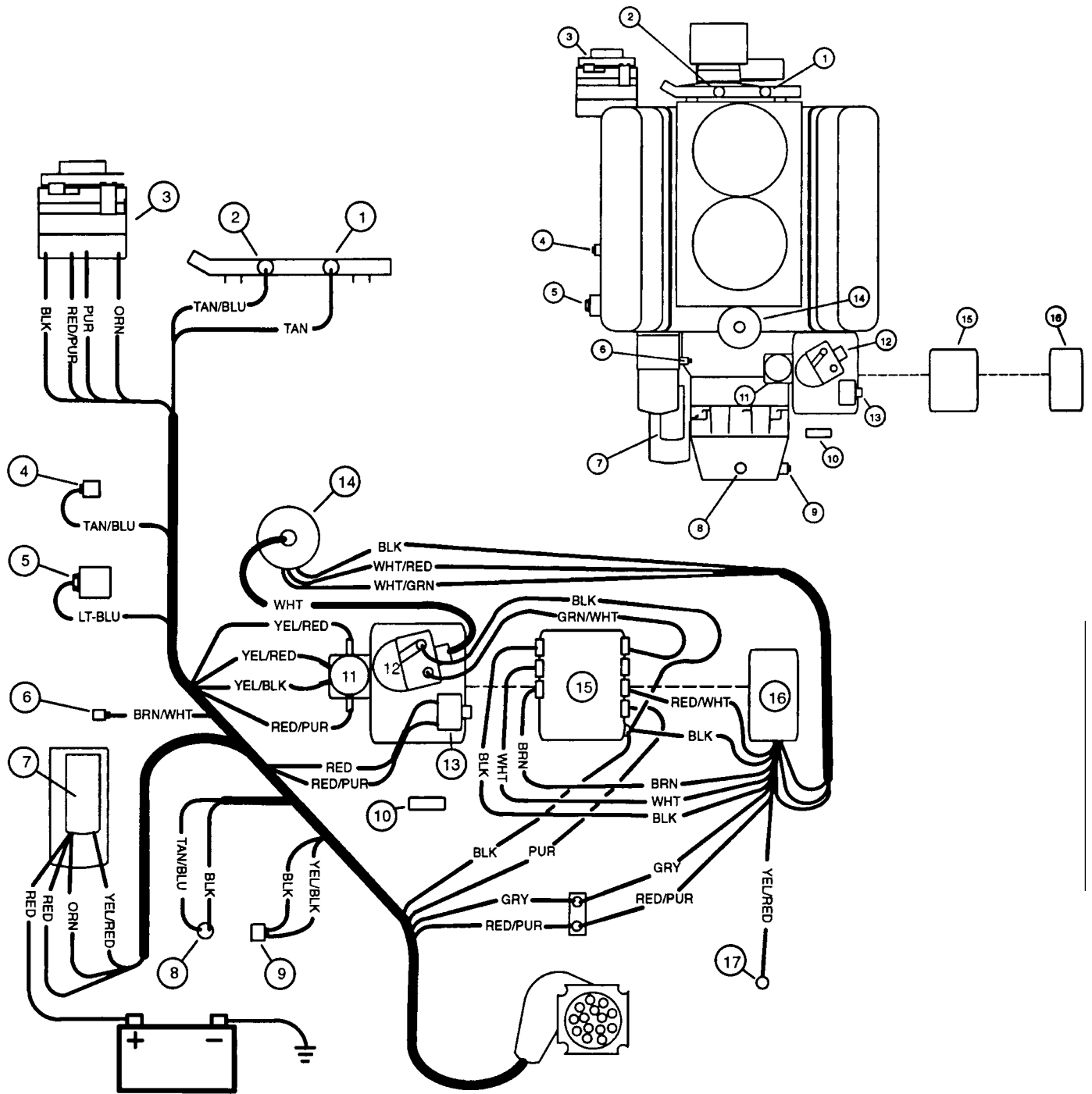

- 1 - Water Temperature Sender
- 2 - Audio Warning Sender (Water)
- 3 - Alternator
- 4 - Low Oil Pressure Audio Warning Sender
- 5 - Oil Pressure Sender
- 6 - Oil Temperature Sender
- 7 - Starter Solenoid
- 8 - Transmission Temperature Audio Warning
- 9 - Neutral Safety

- 10 - Service Monitor (See NOTE)
- 11 - Solenoid
- 12 - Coil
- 13 - Circuit Breaker
- 14 - Distributor
- 15 - Switch Box
- 16 - Timing Module
- 17 - Not Used (Tape Off)

NOTE: Route the Service Monitor Wire into the coil box and wrap monitor wire around the white coil wire 4 or 5 times and secure with a strap. The monitor operates from the current picked up thru the coil wire.

COOLING SYSTEM WATER FLOW DIAGRAM 900 SC

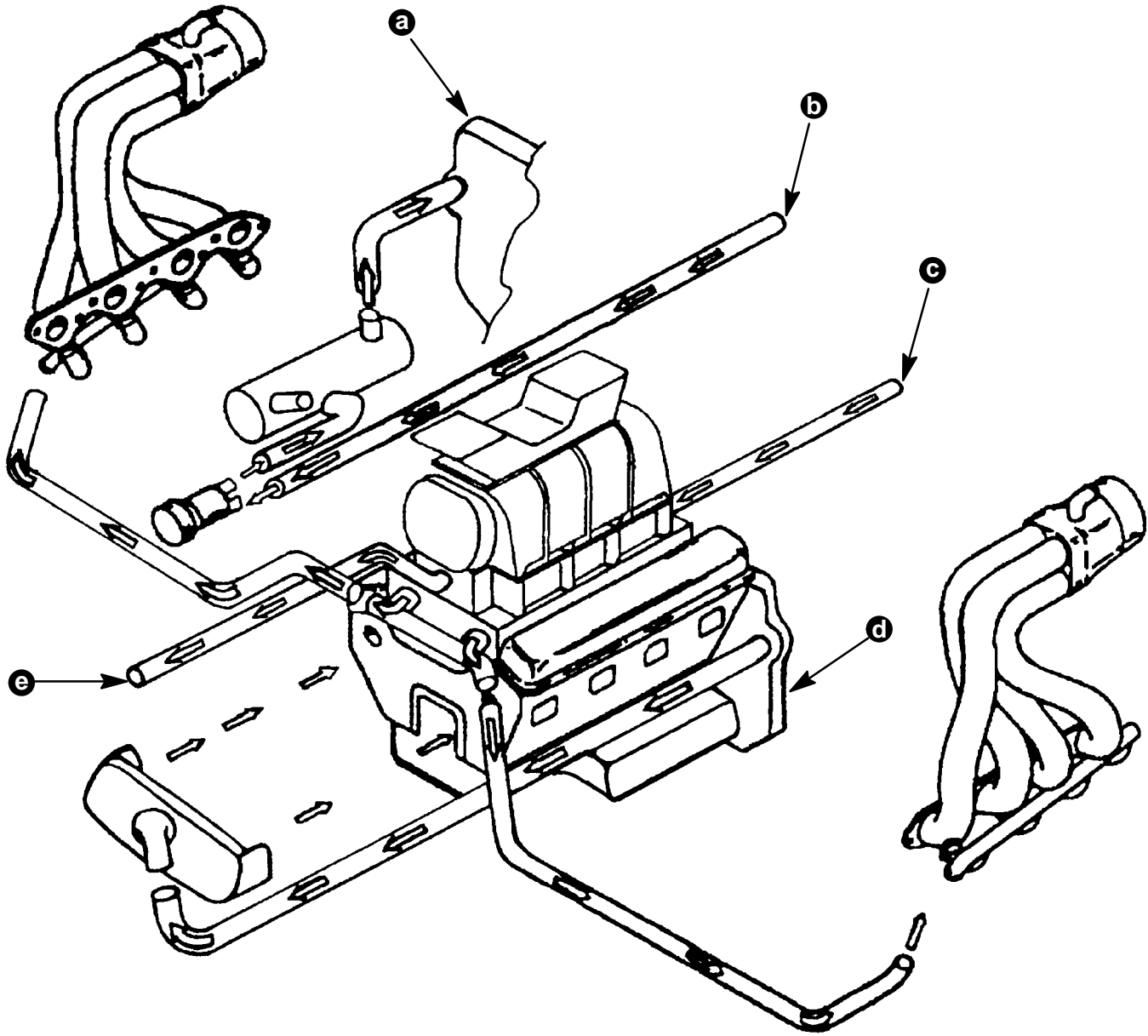

- a - Bell Housing Oil Cooler (Starboard)
- b - Inlet Water (From Sea-Water Pickup) To Engine
- c - Inlet Water (From Sea-Water Pickup To Intercooler
- d - Bell Housing Oil Cooler (Port)
- e - Outlet Water From Intercooler (Overboard)