

WARRANTY INFORMATION

SERVICE INFORMATION

377 Hi-Performance Bravo Sterndrive Specifications

Models Affected

Engine Serial Number 0L416146 & Up.

Octane Requirements

FUEL TYPE	MINIMUM POSTED OCTANE
Unleaded premium	(R+M)÷2=92 or RON=98

Crankcase Oil Recommendations

PREFERRED OILS	API CLASSIFICATION
Quicksilver 4-Cycle Marine Engine Oil (25W-40)	SJ, CF/CF-2
Premium grade multi-viscosity 20W-50 automotive oil	SJ, CF/CF-2
OTHER RECOMMENDATIONS IF PREFERRED OILS ARE NOT AVAILABLE	
Premium multi-viscosity 20W-40 automotive oil	SJ, CF/CF-2
Straight weight detergent automotive oil of correct viscosity (See Chart)	SJ, CF/CF-2
Oil filter should always be changed with oil	

IMPORTANT OIL PRACTICES

Do Not Use
• Non-detergent oils
• Oils containing solid additives
• Multi-viscosity oils other than the ones recommended
• Low quality oils
Do Not Mix
• Straight weight and multi-viscosity oils
• Different brands of oils, straight weight or multi-viscosity
• Different weights of straight weight or different weights of multi-viscosity oils.

Crankcase Oil (con't)

TEMPERATURE/OIL VISCOSITY CHART

Straight Weight Oils SJ,CF/CF-2					30			
							40	
Multi-viscosity Oils SJ, CF/CF-2			Quicksilver 25W 40					
			20W 50					
Air Temp	° F	-20	0	+20	+40	+60	+80	+100
	° C	-30	-20	-10	0	+10	+20	+30

Capacities

Crankcase Oil Capacity w/New Filter ¹	5 U.S. Qts. (4.7 L)
Drive Unit Oil Capacity (w/Monitor)	2.8 U.S. Qts. (2.65 L)
Seawater Cooling System ²	15 U.S. Qts. (14.2 L)

¹ Always use dipstick to determine exact quantity of oil required.

² Seawater Cooling System capacity information is for winterization use only.

Engine Specifications

Engine Type/Rotation	V-8	LH
Displacement CID/Ltr	377 (6.2)	
Propshaft Horsepower	350	
Propshaft Horsepower (Kilowatts)	261	
Bore	4.00 in. (101.6 mm)	
Stroke	3.75 in. (95.25 mm)	
Compression Ratio	9.0:1	
Compression Pressure	150 - 170 psi (1034 - 1172 kPa)	
Maximum RPM @ WOT ¹	4800-5200	
Oil Pressure @ idle RPM	30-70 psi (207-483 kPa)	
Minimum Oil Pressure @ 2000 RPM	20 psi (138 kPa)	
Thermostat	140° F (61° C)	
Accessories Belt Style	Serpentine	

¹ Engines are equipped with an ignition system that have a built-in 5400 RPM rev limiter. Engine is performing normally if it will not exceed this RPM.

Tune Up Specifications

Spark Plug Type	AC-MR43LTS, NGK BPR6EFS, Champion RS12YC
Spark Plug Gap	.045 in. (1.1mm)
Idle RPM in or out of Gear	750 Minimum
Timing @ Idle RPM	8° BTDC (See Note)
Firing Order	1-8-4-3-6-5-7-2
Electrical System	12-Volt Negative (-) Ground
Alternator	65 Amps
Valve Lash	3/4 turn down from zero lash
Recommended Battery Rating	Minimum 550 CCA, 700MCA or 120 Amp/Hrs

Note: Use Digital Diagnostic Tool (DDT) 91-823686A2 to lock the timing in while checking timing.

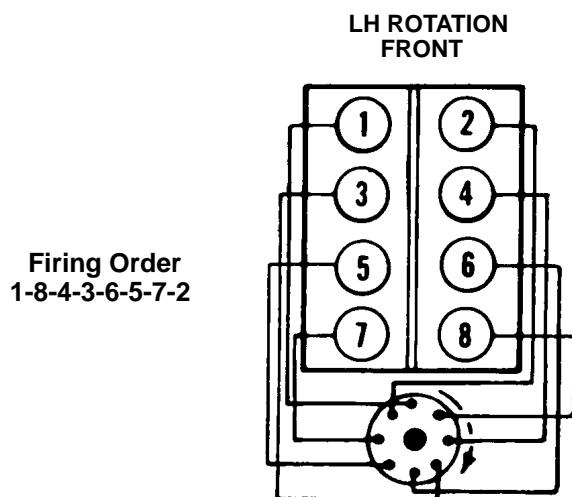

Electrical Specifications

IGNITION SPECIFICATIONS

Coil	Part No. 817378
Coil Primary Resistance (Ohms)	.4
Coil Secondary Resistance (Ohms)	8250

STARTER MOTOR SPECIFICATIONS

Mercury Marine Part No.		50-806964A1		
Delco Remy Part No.		9000821		
No Load Test				
Volts	Amps. (Min.)	Amps. (Max.)	RPM (Min.)	RPM (Max.)
10.6	70	120	5400	10,800

Fuel Pump Specifications

Mercury Marine Part No. - Fuel Pump	861156-1
Fuel Pump Type	Electric
Pump Location	Lower Port Side of Engine
Flow @ 30 psi	57.0 GPH
Static Pressure (Deadhead)	120.0 psi. (827 kPa)
Fuel Pump Pressure (Key ON, engine not running)	30 psi. (206.9kPa)
Fuel Pump Pressure at idle	22 psi. (151.7kPa)
Fuel Pump Pressure at W.O.T. (5200 RPM)	27 psi. (186.2kPa)

Internal Engine Specifications

UNIT OF MEASUREMENT: in. (mm)

CYLINDER BORE

Diameter		4.0007-4.0027 (101.618-101.669)	
Out of Round		Production	.0005 (0.12) Max
		Service	.002 (0.05) Max
Taper	Production	Thrust Side	.0005 (0.012) Max
		Relief Side	.001 (0.025) Max
	Service		.001 (0.025) Over Production

PISTON TYPE: HYPEREUTECTIC CAST

PISTON CLEARANCE

Production	.002-.003 (0.051-0.076)
Service	.003-.004 (0.076-0.101)

MEASURING PISTON

Measure piston 2.10 in (53.3 mm) from top of piston.

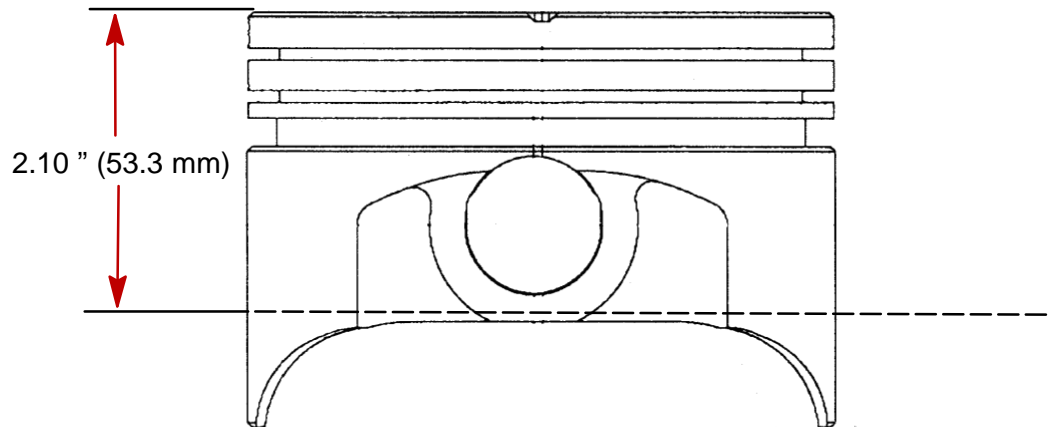

PISTON RING:

COMPRESSION RINGS

Groove Clearance	Production	Top	.0012-.0032 (0.030-0.081)
		2nd	
	Service	Top	High Limit Production +.001 (0.025)
		2nd	
End Gap	Production	Top	.016-.026 (0.40-0.66)
		2nd	
	Service	Top	High Limit Production \pm .010 (.025)
		2nd	

OIL RINGS

Groove Clearance	Production	0.002-0.007 (0.051-0.18)
	Service	High Limit Production \pm .001 (0.025)
Gap	Production	.010-.050 (0.25-1.27)
	Service Limit	High Limit Production \pm .001 (.025)

PISTON PIN

Diameter		.9270-.9271 (23.545-23.548)
Clearance	Production	.0004-.0008 (0.0120-0.0210)
	Service	.0010 (0.025) Max
Fit to Rod		.0008-.0016 (0.021-0.40) Interference

CRANKSHAFT: LUNATI CRANK

Main Journal	Diameter	No. 1, 2, 3, 4, 5	2.4480-2.4485 (62.179-62.192)
	Taper	Production	0.0002 (0.005) Max
		Service	0.001 (0.025) Max
	Out of Round	Production	0.0002 (0.005) Max
Service		0.001 (0.025) Max	
Main Bearing Clearance	Production	No. 1, 2, 3, 4	0.0015-0.003 (0.038-0.076)
		No.5	0.0025-0.0035 (0.0760-0.0380)
	Service	No.1, 2, 3, 4	0.0015-0.003 (0.038-0.076)
		No.5	0.0025-0.0035 (0.0760-0.0380)
Crankshaft End Play			0.002-0.008 (0.0500-0.200)
Connecting Rod Journal	Diameter		2.0990-2.0995 (53.3146-53.3327)
	Taper	Production	0.0003 (0.007)
		Service	0.001 (0.025) Max.
	Out of Round	Production	0.0003 (0.007)
		Service	0.001 (0.025) Max.
	Rod Bearing Clearance		Production
Service			0.002-0.003 (0.050-0.076)
Rod Side Clearance			.008-.017 (0.20-0.43)
Crankshaft Runout			0.0002-0.0015 (0.005-.038)

CAMSHAFT AND DRIVE:

Lobe Lift \pm .002 (0.051)	Intake	0.340 (8.636)
	Exhaust	0.3534 (8.9763)
Duration at .050 In. (1.27mm) Cam Lift	Intake	222°
	Exhaust	230°
Journal Diameter		1.8682-1.8692 (47.440-47.490)
Timing Chain Deflection [LH Rotation]		0.375 (9.5) from taut position [total .75 (19)]

VALVE SYSTEM:

Lifter Type		Roller Hydraulic	
Rocker Arm Ratio		1.50 to 1	
Valve Lift	Intake	0.510 (12.95)	
	Exhaust	0.530 (13.46)	
Valve Lash (Intake and Exhaust)		3/4 Turn Down from Zero Lash	
Face Angle	Intake	45°	
	Exhaust	45°	
Seat Angle	Intake	45°	
	Exhaust	45°	
Seat Runout (Intake & Exhaust)		.002 (0.05) Max	
Seat Width	Intake	0.040-0.065 (1.02-1.65)	
	Exhaust	0.065-0.098 (1.65-2.49)	
Stem Clearance	Production	Intake	0.0010-0.0027 (0.025-0.069)
		Exhaust	0.0010-0.0027 (0.025-0.069)
	Service	Intake	High Limit Production + .001 (0.025)
		Exhaust	High Limit Production + .0002 (.0050)
Stem Diameter	Intake	0.341 (8.66)	
	Exhaust	0.341 (8.66)	
Valve Diameter	Intake	1.94 (49.28)	
	Exhaust	1.50 (38.1)	
Valve Margin After Surfacing - Intake and Exhaust		0.031 (0.79) Minimum	

VALVE SPRING

Valve Spring: Single Coil Ovate Wire	Number of Springs		1
	Free Length		2.170 (51.2)
	Pressure	Valve Closed	90-100 lbf. (400-445 N) at 1.8 (45.7)
		Valve Open	265-275 lbf. (1179-1223 N) at 1.27 (32.3)
	Installed Height	Intake	1.785-1.815 (45.34-46.10)
		Exhaust	1.785-1.815 (45.34-46.10)
	Approximate Number of Coils		5

CYLINDER HEAD:

Surface Flatness (at exhaust manifold deck)	0.0019 (0.0483)
Surface Flatness (at engine block deck)	0.004 (0.10) Overall Maximum
Surface Flatness (at intake manifold deck)	0.004 (0.10) Overall Maximum

FLYWHEEL:

Run Out on Face Area	.008 (0.203) Max
----------------------	------------------

Tightening Torque and Lubes

DESCRIPTION	TORQUE			LUBRICANTS, SEALANTS, LOCTITE NO. & COLOR
	lb. in.	lb. ft.	N·m	
Alternator Brace to Alternator	192		28	
Alternator Brace to Engine		30	41	
Alternator to Mounting Bracket		35	48	
Alternator Mounting Bracket to Block		30	41	
Camshaft Sprocket/Gear	216	18	24	Loctite 271 - Red
Camshaft Thrust Plate Retainer Bolts	106		12	
Connecting Rod Caps (1st Pass) (Final pass)		20 45	27 61	Apply moly lube on washer, under bolt head & on threads
Crankshaft Pulley		43	58	
Cylinder Head Bolts (1st Pass) (2nd Pass) (Final Pass)		26 44 70	35 60 95	PTFE Sealant on Threads and Under Head of Bolt
Distributor Clamp		25	34	
Exhaust Manifold to Head		35	47	
Exhaust Riser to Manifold		35	47	
Flywheel		70	95	Loctite 271 - Red
Flywheel Coupler		35	48	Loctite 271 - Red
Flywheel Housing		30	41	
Flywheel Housing Cover	80		9	
Front Mount Bracket		30	41	
Intake Manifold (1st pass) (2nd pass) (Final pass)	27 106 132		3 12 15	
Intake Plenum to Manifold		10	14	
Lifter Guide Retainer		18	25	Loctite 271 - Red

DESCRIPTION	TORQUE			LUBRICANTS SEALANTS, LOCTITE NO. & COLOR
	lb. in.	lb. ft.	N·m	
Main Bearing Caps (1st pass) (2nd pass) (Final pass)		15 50 74	20 68 102	Apply moly lube on washer, under bolt head & on threads
Oil Baffle Nuts		25	34	Loctite 271 - Red
Oil Filter Adapter Bolt		15	20	
Oil Pan Bolt	106		12	
Oil Pan Nut		18	25	
Oil Pan Stud	53		6	
Oil Pan Drain Plug		18	25	
Oil Pump		65	88	Loctite 271 - Red
Oil Pump Cover	106		12	Loctite 271 - Red
Power Steering Pump Brace to Block		30	41	
Power Steering Pump Bracket				
Rear Crankshaft Oil Seal Assembly	106		12	
Rear Mount		40	54	
Re-circulating Pump		33	45	
Remote Oil Filter Adapter Nut/Fitting		20	27	
Rocker Adjusting Nut		17	23	
Rocker Arm Studs		25	34	Loctite #35 - Green with Primer NF
Seawater Pump Brace		30	41	
Seawater Pump Bracket				
Spark Plugs		15	20	
Starter to Cyl. Block		30	41	
Thermostat Housing		30	41	
Throttle Body to Intake Plenum	132		15	
Timing Chain Cover Bolts	106		12	
Torsional Damper		60	81	Loctite 271 - Red
Valve Cover Bolts	106		12	
Water Temperature Sender		20	27	

Cylinder Head Torque Sequence

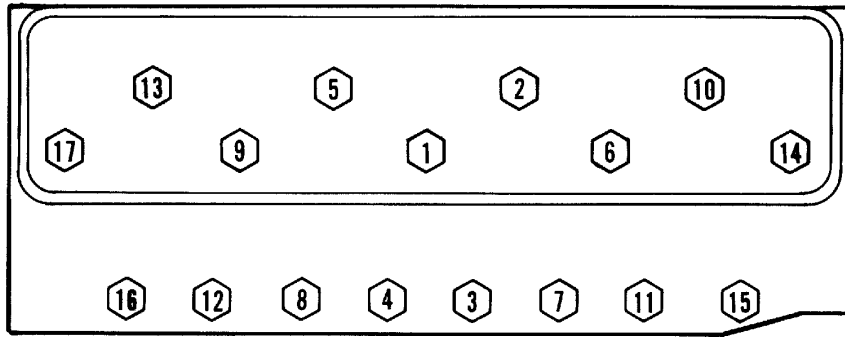

72332

Intake Manifold Torque Sequence

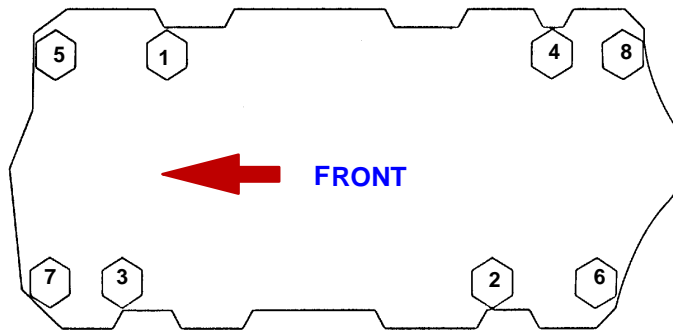

72878

Serpentine Belt Routing/Tension

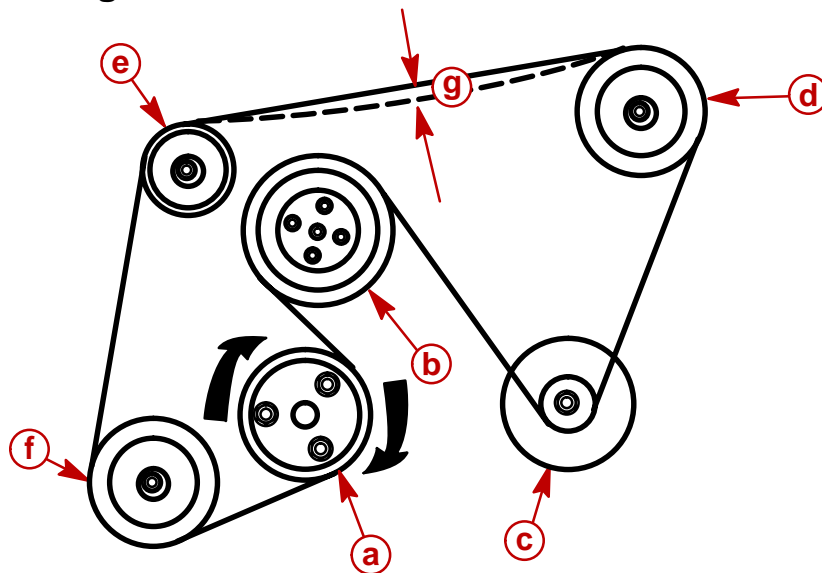

- a** - Crankshaft Pulley
- b** - Water Circulating Pump Pulley
- c** - Alternator Pulley
- d** - Power Steering Pump Pulley
- e** - Idler Adjustment Pulley
- f** - Seawater Pump Pulley
- g** - Belt Tension: 1/2" (13 mm) Deflection Using Moderate Thumb Pressure

Wiring Diagrams

EFI & Ignition System

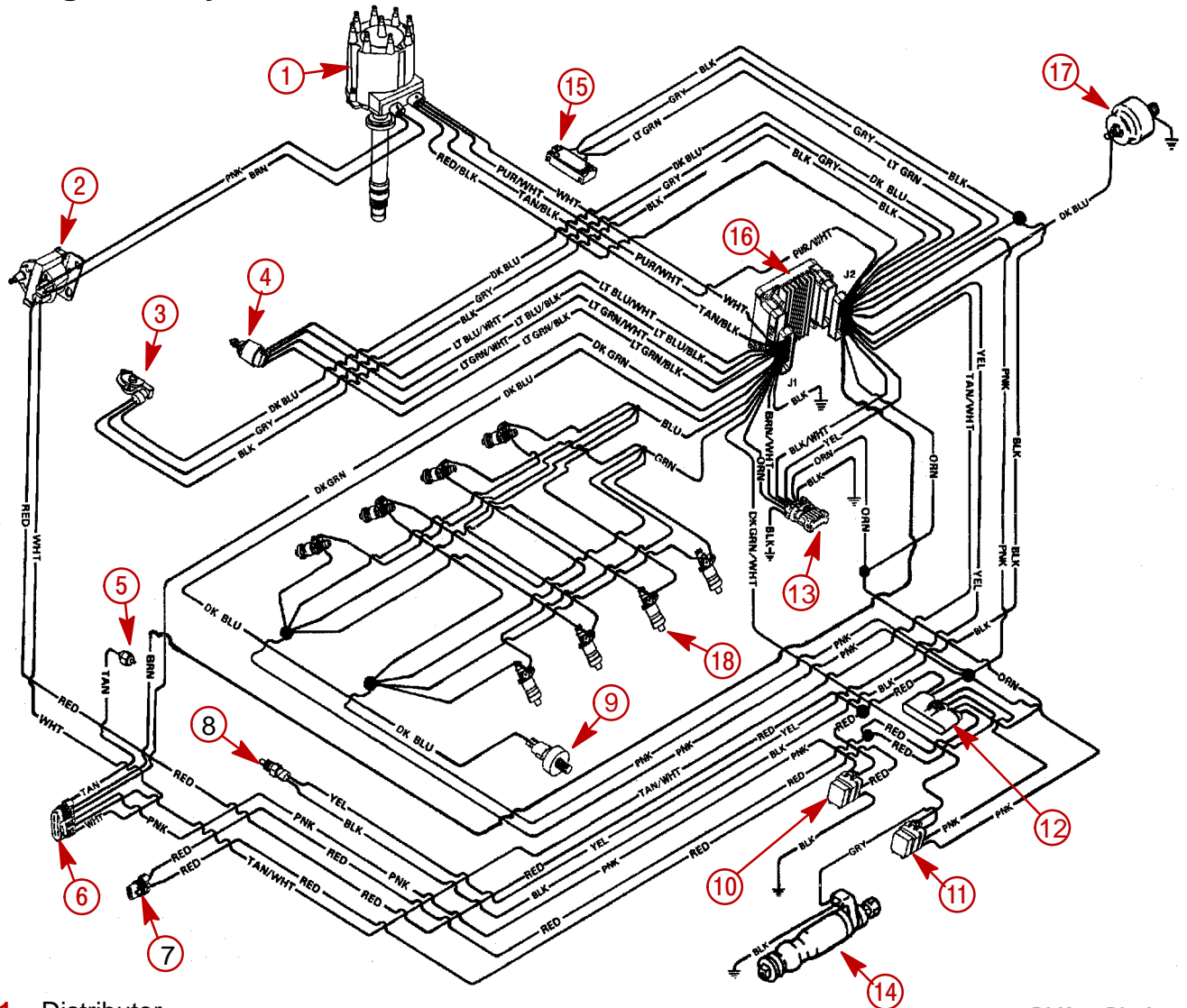

- 1 - Distributor
- 2 - Coil
- 3 - Throttle Position Sensor
- 4 - Idle Air Controller
- 5 - Water Temp. Sender to Gauge
- 6 - To Start & Charging Harness
- 7 - 12V Supply to Harness
- 8 - Coolant Temp. Sensor
- 9 - Knock Sensor
- 10 - Ignition Relay
- 11 - Fuel Pump Relay
- 12 - Fuse Block
- 13 - ALDL Connector
- 14 - Fuel Pump
- 15 - Manifold Absolute Pressure Sensor
- 16 - ECM
- 17 - Oil Pressure Switch (Warning System)
- 18 - Fuel Injector(s)

- BLK = Black
- BLU = Blue
- BRN = Brown
- GRY = Gray
- GRN = Green
- ORN = Orange
- PNK = Pink
- PUR = Purple
- RED = Red
- TAN = Tan
- WHT = White
- YEL = Yellow
- LIT = Light
- DRK = Dark

Wiring Diagrams (cont.)

Starting & Charging System

A - Drive Oil System

- 1 - Oil Reservoir

B - Instrumentation System

- 1 - Oil Pressure Sender for Gauge
- 2 - Trim Position Sender

C - Charging And Starting System

- 1 - Alternator
- 2 - Ground Stud
- 3 - Starter Motor
- 4 - Battery
- 5 - Circuit Breaker
- 6 - Starter Slave Solenoid
- 7 - Harness Connector To Fuel Injection System Harness
- 8 - Positive (12V) Power Wire To Fuel Injection System Harness
- 9 - Auxiliary Tachometer Lead
- 10 - 90 Amp. System Fuse (DO NOT Remove)

BLK = Black	PUR = Purple
BLU = Blue	RED = Red
BRN = Brown	TAN = Tan
GRY = Gray	WHT = White
GRN = Green	YEL = Yellow
ORN = Orange	LIT = Light
PNK = Pink	DRK = Dark

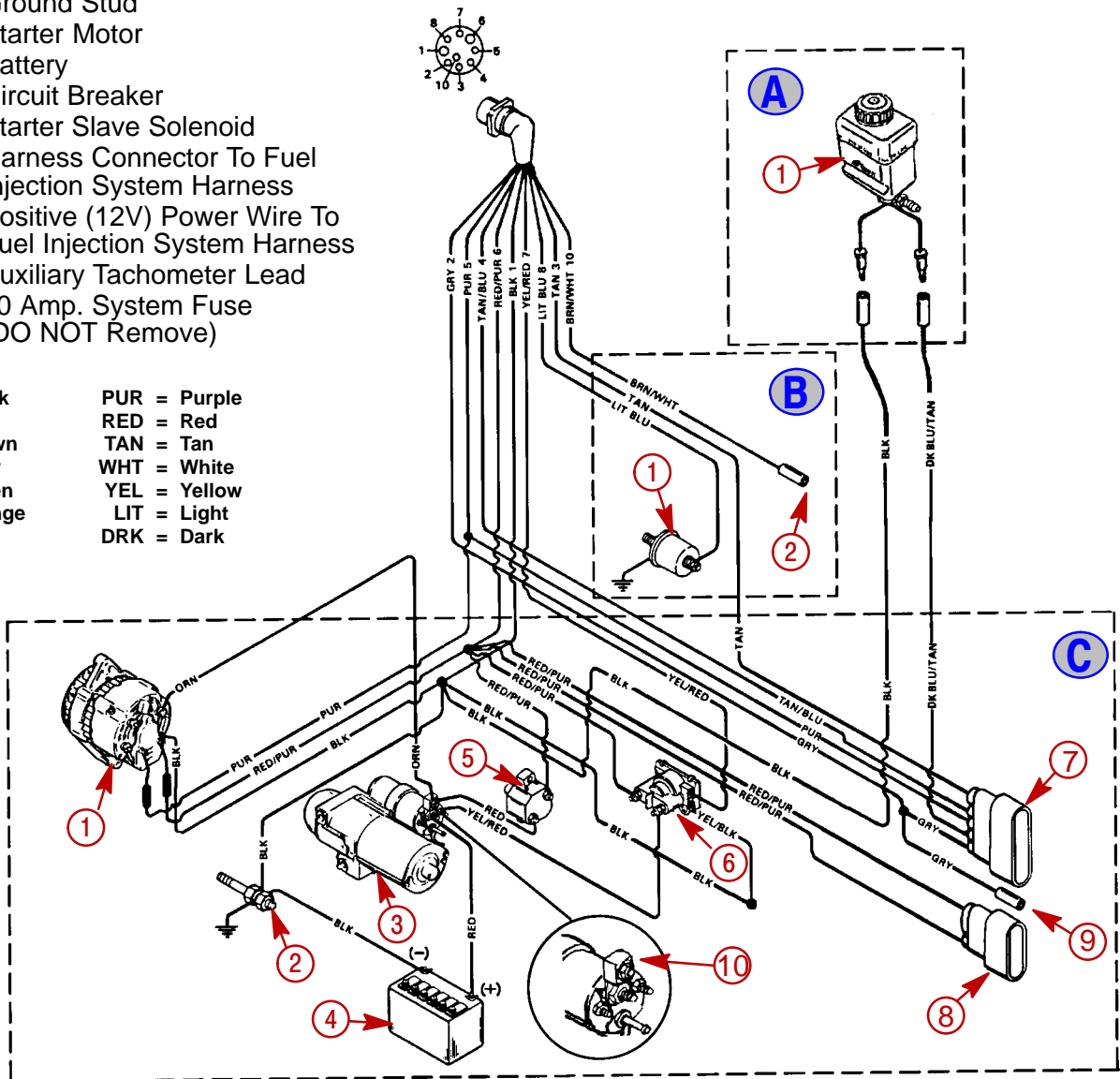

Water Flow Diagram

- a** - Seawater Inlet
- b** - Power Steering Cooler
- c** - Seawater Pickup Pump
- d** - Thermostat Housing
- e** - Engine Circulating Pump
- f** - Fuel Cooler
- g** - To Exhaust Elbows
- h** - To Exhaust Manifold
- i** - To Engine Circulating Pump
- j** - Coolant From Engine
- k** - From Seawater Pickup Pump
- l** - Coolant Flow With Thermostat Closed
- m** - Coolant Flow With Thermostat Open

