



# parts bulletin

**MERCURY**  
HI-PERFORMANCE

**QUICKSILVER**  
MARINE PARTS AND ACCESSORIES

No. 96-9

REVISED 9-29-98

## SPORTMASTER, CLE GEARHOUSING STUD APPLICATIONS

**IMPORTANT:** Hi-Performance Sportmaster and CLE basic service gear housings are sold without mounting studs. The correct studs must be ordered from chart below.

1. Clean studs with Loctite Primer and apply Loctite #271 only to threads of stud installed into lower gearcase.
2. Use a stud installation tool and thread stud into lower gearcase. Tighten securely.

Lower Gearcase Stud Installation Locations

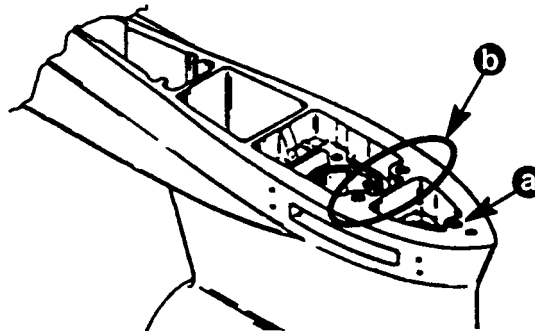

**IMPORTANT:** Studs have different threads on either end. Ensure to thread the coarse threaded end into the lower gearcase.

Upper Gearcase Style #1	Application	Stud Location	Quantity	Stud Part Number	Stud Length
	Required Per Gearcase	a	1	16-78638	3 1/8" (3.12)
		b	2	16-57920	2 1/16" (2.06)
	Required Per Gearcase (when using a 5" spacer)	a	1	16-78639	8 1/8" (8.12)
		b	2	16-74730	7 1/16" (7.06)
Upper Gearcase Style #2	Required Per Gearcase	a & b	3	16-59579	2 13/16" (2.81)
	Required Per Gearcase (when using a 5" spacer)	a & b	3	16-74732	7 11/16" (7.69)